

Laureate™ True AC RMS Voltage & Current Panel Meters

0.2 V - 660 V and 2 mA - 5 A full-scale ranges



Features

- 0.2, 2, 20, 200 & 660 V ranges
- 2, 20, 200 mA & 5 A ranges
- 4 1/2 digit resolution
- 99.9% accuracy of full scale
- AC coupled input
- Crest factor of 2.4 at full scale
- Priced competitively with less capable averaging AC meters
- Scalable for direct readout of external current shunts or current transformers
- Peak value display
- 85-264 Vac and 90-370 Vdc power standard
- Green or red display
- Choice of isolated plug-in options for control and computer interface:
[dual relays](#), [4-20 mA & 0-10 V analog output](#), [RS-232/485 I/O](#), [parallel BCD output](#), [low voltage AC & DC power](#).
- [NEMA 4X, 1/8 DIN case](#).
- Certified to UL 3101-1, CAN/CSA-C22.2, EN 61010-1 (CE Mark).

Description



The Laureate™ True RMS meter offers a high accuracy 4 1/2 digit display for five voltage ranges and four current ranges. It is suited for AC applications where there is considerable distortion of current waveforms from nonlinear loading. The input is AC coupled to read only the AC component, such as ripple on a power supply.

The True RMS meter uses precision circuitry to compute the root-mean-square of complex waveforms from 10 Hz to 10 kHz. Spikes up to 2.4 times the maximum of each range are accurately measured. This provides a crest factor (V_p / V_{rms}) of 240 for a signal amplitude of 1% of full scale, decreasing to 2.4 at 100% of full scale.



Use with Current Transformers

High common mode rejection allows stable readings with current shunts located on the high side of the line. Five amp input capability allows the output of 5 A current transformers to be applied directly to the meter, with no need for a stepdown transformer. The current reading can easily be scaled to display the input to the current transformer. Digital scaling and calibration eliminate zero and span drift associated with potentiometers in non-microcomputer based meters.

High Accuracy

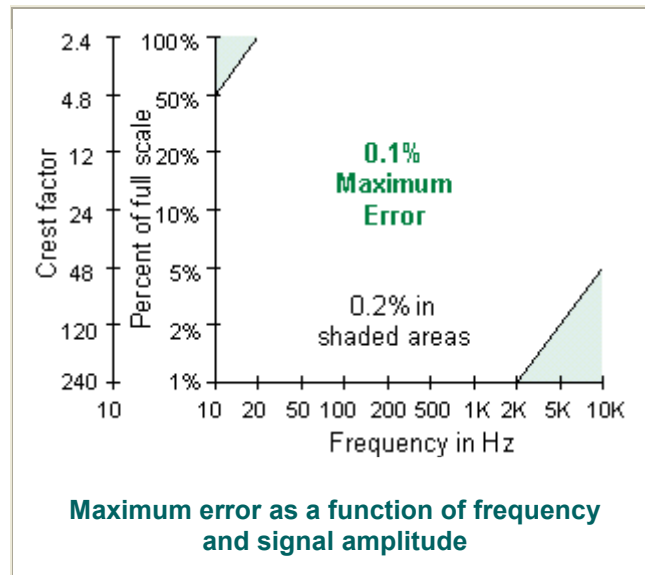

The typical accuracy is 99.9% of full scale, decreasing to 99.8% for low frequency at high amplitude, or high frequency at low amplitude. The above graph shows that maximum error is 0.1% of full scale over all frequency ranges of interest to AC power measurement. Error increases to 0.2%, represented by the two shaded areas, at low frequency and high amplitude, or high frequency and low amplitude.

Crest factor increases in inverse proportion to signal amplitude. As shown on the same graph, the maximum crest factor (V_p / V_{rms}) is 2.4x at full-scale amplitude, increasing to 240 at 1% of full-scale amplitude.

The Laureate RMS meter utilizes the same high-speed analog-to-digital conversion method as all other Laureate panel meters. However, the meter settling time and control response to a step change in AC amplitude are limited by the RMS converter circuit to approximately 1 second.

Interface Options

Plug-in [isolated analog output](#), [dual setpoint controller](#), [RS-232/485 communications](#), or [BCD output](#) boards can upgrade the Laureate from a simple monitor to system interface and control.

Built-in Flexibility & Safety

Laureates may be powered from [85-264 Vac and 90-370 Vdc](#), or optionally from [8-28 Vac and 9-37 Vdc](#). They are available with red or green LEDs. They are housed in a [1/8 DIN case](#) that meets NEMA 4X (IP65) specifications from the front when panel mounted. Any setup functions and front panel keys may be locked out for simplified usage and security.

Specifications

AC Voltage (1% to 100% of full scale)

AC Voltage Range	Resolution	Input Ohms	Typ Error at 25°C
200.00 mV	10 μ V	22 M	0.1% FS \pm count, 10 Hz to 10 kHz
2.000 V	100 μ V	22 M	
20.000 V	1 mV	1 M	
200.00 V	10 mV	1 M	
660.0 V	100 mV	1 M	

AC Current (1% to 100% of full scale)

AC Current Range	Resolution	Input Ohms	Typ Error at 25°C
2.0000 mA	0.1 μ A	100	0.1% FS \pm count, 10 Hz to 10 kHz
20.000 mA	1.0 μ A	10	
200.00 mA	10 μ A	1	
5.000 A	1.0 mA	0.01	

AC Voltage & Current

Display	
Readout	5 digits, 7-segment, 14.2 mm (.56")
Color	Red or green LED
Range	-99999 to +99999 or -99990 to +99990 (count by 10 with rounding)
Indicators	2 red LED lamps
Accuracy	
Span Tempco	0.005% of reading/ $^{\circ}$ C
Zero Tempco	0.1 counts/ $^{\circ}$ C
Crest Factor	2.4x at 100% of full scale
Response Time	
RMS to DC	1 s conversion settling time
A-to-D rate	60/s at 60 Hz, 50/s at 50 Hz
Output Update	56/s at 60 Hz, 47/s at 50 Hz
Display Update	3.5/s at 60 Hz, 3/s at 50 Hz
Maximum Signal	
Max applied voltage	660 Vac for 20, 200 and 600 V ranges, 125 Vac for other ranges
Overcurrent protection	25x for 2 mA, 8x for 20 mA, 2.5x for 200 mA, 1x for 5 A
Power	
Voltage, std.	85-264 Vac and 90-370 Vdc
Voltage, opt.	8-28 Vac and 9-37 Vdc
Frequency	DC or 49-440 Hz

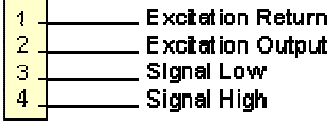
Power isolation	Safety-rated to 250 Vac, meter ground to earth ground, DC to 60 Hz, 4.2 kVp per High Voltage Test
Excitation Output	
5 Vdc 10 Vdc 24 Vdc Output isolation	5 Vdc $\pm 5\%$, 100 mA max 10 Vdc $\pm 5\%$, 120 mA max 24 Vdc $\pm 5\%$, 50 mA max 50 Vdc to meter ground
Connector Pin Assignments	
	
Environmental	
Operating Temperature Storage Temperature Relative Humidity Protection	0°C to 55°C -40°C to 85°C 95% at 40°C, non-condensing NEMA-4X (IP-65) when panel mounted

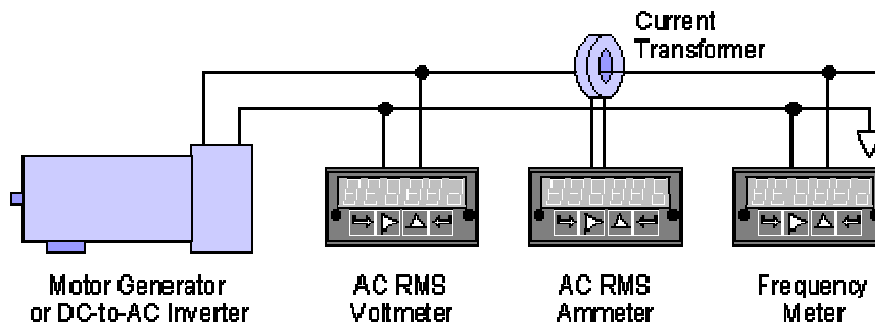

Using Laureate Meters and Counters to Instrument an AC Line

Why Measure AC Power?

Many AC loads, such as electrical motors, will only operate reliably if the AC line voltage and frequency are within specified tolerances. Otherwise permanent damage to expensive plant equipment may occur. Motor generators and UPS systems will only operate reliably with the load for which they are rated. Drops in line voltage or frequency may indicate an excessive load and the possibility of equipment damage.

Laureate meters and counters are low-cost means to instrument AC power lines with great accuracy:

- **AC RMS Voltmeter.** Full-scale ranges of interest are 200.00 V with 10 mV resolution and 660.0 V with 100 mV resolution. True RMS capability allows the display of RMS voltage for non-sinusoidal waveshapes, such as square waves from a UPS.
- **AC RMS Ammeter.** A built-in 5 A range can be used to display currents up to 5.000 A with 10 mA resolution, or to accept the output of 5 A current transformers. The 200.00 mV range can be used with external current shunts. With either transformers or shunts, scaling to the input current is easily accomplished via the meter's front panel pushbutton switches.
- **Frequency Meter.** Inverse period is used to determine AC line frequency to six-figure accuracy (60.0000 or

50.0000) in a few line cycles plus 30 ms.

- **Phase Angle Meter.** Two signals with identical periods are applied to Channels A and B of the Laureate phase angle meter. A display from -180° to $+180^\circ$ is obtained by timing the rising edge of one channel and the falling edge of the other channel. A resolution of 1° , 0.1° or 0.01° is selectable. Accuracy is .01% up to 100 Hz, .1% at 1 kHz, and 1% at 10 kHz.

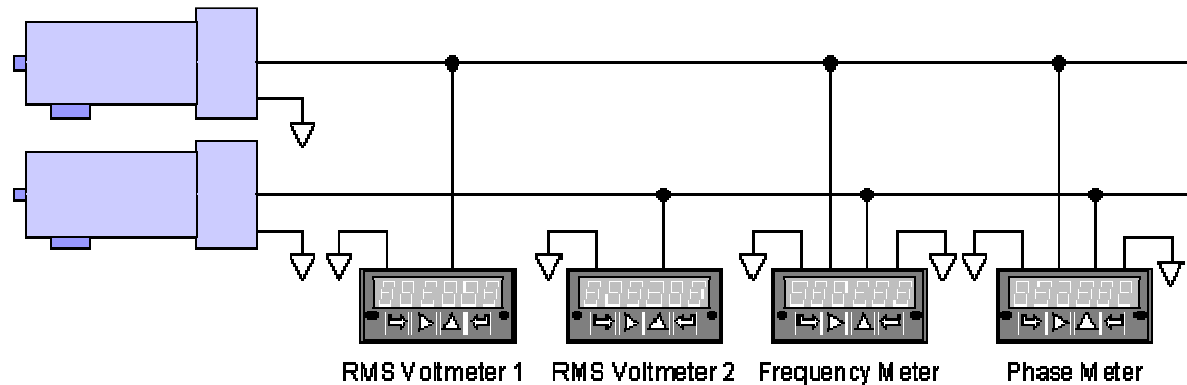

Using Laureate Meters to Synchronize Motor Generators

Successful synchronization of two motor generators requires that the voltage outputs of the generators be close to each other, that the two frequencies be identical, and that the voltage waveshapes be in phase.

- **The two voltages** can be measured by two Laureate AC RMS Voltmeters, which offer 200.00 V and 660.0 V ranges. Or a single meter can be multiplexed by using an external toggle switch.
- **The two frequencies** can be measured to six-figure accuracy by a single [Laureate Dual Channel Counter](#), where each channel monitors a generator. The two AC neutrals must be tied to meter ground. Pressing a front-panel key toggles the reading between the channels.
- **Phase angle** can be measured using the [Laureate Phase Meter](#).

Ordering Guide

Laureate™ True AC RMS Voltage & Current Panel Meters

Create a model number in this format: **L10010RMV1**. This example calls out a Laureate panel meter with a standard main board with green LEDs, 85-264 Vac & 90-370 Vdc power, no setpoint output, 0-20 mA & 0-10 V analog outputs, no digital interface, and an RMS signal conditioner set for 200.00 mV. Includes plug-in screw terminals.

DPM Type	L Digital Panel Meter.	\$210
Main Board	1 Standard Main Board, Green LEDs.	NC
	2 Standard Main Board, Red LEDs.	NC
Note: Extended capability is required for custom curve linearization or for display of time rate of change, such as flow rate from changing tank level or acceleration from changing speed. Not applicable to temperature.		
Power	0 Isolated 85-264 Vac & 90-370 Vdc	NC
	1 Isolated 8-28 Vac & 9-37 Vdc.	\$30

Setpoint Output	<input checked="" type="checkbox"/>	0 None.		NC	
	<input type="checkbox"/>	1 Dual 10A Contact Relays.		\$80	
	<input type="checkbox"/>	2 Isolated Dual Solid State Relays.		\$55	
Analog Output	<input checked="" type="checkbox"/>	0 None.		NC	
	<input type="checkbox"/>	1 Isolated 0-20 mA & 0-10 V.		\$90	
Digital Interface	<input checked="" type="checkbox"/>	0 None.		NC	
	<input type="checkbox"/>	1 Isolated RS-232.		\$60	
	<input type="checkbox"/>	2 Isolated RS-485.		\$80	
	<input type="checkbox"/>	3 Isolated Parallel BCD Output.		\$105	
	<input type="checkbox"/>				
Signal Input	True AC RMS Volts				
	<input type="checkbox"/>	RMV1 200.00 mV.		\$35	
	<input type="checkbox"/>	RMV2 2.0000 V.			
	<input type="checkbox"/>	RMV3 20.000 V.			
	<input type="checkbox"/>	RMV4 200.00 V.			
	<input type="checkbox"/>	RMV5 600.0 V			
	True AC RMS Amps				
	<input type="checkbox"/>	RMA1 2.0000 mA.		\$35	
	<input type="checkbox"/>	RMA2 20.000 mA.			
	<input type="checkbox"/>	RMA3 200.00 mA.			
	<input type="checkbox"/>	RMA4 5.000 A.			
	Note: The same AC RMS signal conditioner can be user configured for AC Volts or AC Amps. It is precalibrated in EEPROM for all AC Volt and AC Amp ranges listed.				
	Add-on Options	<input type="checkbox"/>	EB Extra Bright Red LED Display.	<input type="checkbox"/> Unselected.	\$30
		<input type="checkbox"/>	BL Blank Lens without Button Pads.	<input type="checkbox"/> Unselected.	NC