



Features

Measurement, display and communication of up to 103 electrical and power parameters

High contrast LCD display with LED backlight

True RMS measurement

Pulsed, analog and digital communications

Modbus, Johnson Controls and Lonworks interface options

Fully programmable PT and CT ratios

Benefits

Replaces multiple single function instruments

Significant cost savings

Reduced wiring times

Simple menu driven interface

User definable outputs and scaling

Accurate at 4 quadrant power factors

Import and export monitoring

Applications

Switchgear

Distribution systems

Generator sets

Control panels

Embedded generation

Energy management

Building management

Utility power monitoring

Process control

Motor monitoring

Feeder panels

Distribution pillars

Compliant With

IEC1010/BSEN 61010-1

IEC 664, VDE 0110, PD 6499

Multi function Integra 2000 replaces the need for numerous single function instruments, providing significant cost savings and reduced wiring times for all power monitoring applications. Integra 2000 digital metering systems provide high accuracy true RMS measurement and display of up to 103 electrical and power quality parameters.

Status information can be monitored via the high contrast graphical LCD display with LED backlight, which is ideally suited for low ambient light conditions. Alternatively, optional pulsed, analog and digital communication outputs allow status information of measured parameters to be communicated into building management systems.

Operation

A five button menu driven interface on the front panel of Integra 2000 units provides simple programming of PT and CT ratios, configuration of selected communication options and adjustment of operating parameters.

Integra 2000 provides simple and quick access to the measured electrical data, with active reading screens typically presented in a 4 line 4 digit format. The default screen is factory set to display Volts, Amps, Frequency and Watts, but can be customized to display any four measured parameters. User-friendly soft prompts are assigned to each of the four main parameter buttons, guiding the user easily through the menu structure to configure and monitor chosen parameters with a minimum number of button presses.

To prevent unauthorized access to the product configuration settings, all set up screens offer password protection. Once configured, status information can be viewed by scrolling through up to 42 backlit dot-matrix LCD screens featuring different character font sizes for maximum clarity of information. Optional pulsed, analog or digital outputs allow status information of measured parameters to be communicated into building management systems.

System Input

Designed for all low, medium and high voltage switchgear and distribution systems, the Integra 2000 offers programmable PT and CT ratio capability. Suitable for direct connection to many common voltages with 5A CT inputs.

System Outputs

Pulsed Outputs

Integra 2000 offers two pulsed outputs enabling the retransmission of time-based parameters. Each relay can be assigned to kW.Hr or kVAr.Hr (import or export) kVA.Hr and kA.Hr, and will pulse at a rate proportional to the measured active energy, with pulse width and rate easily programmable. The output relays have fully isolated volt free contacts, with connection via screw clamp terminals.

Analog Outputs

Four analog outputs may also be included, enabling onward transmission of linear parameters using industry standard analog signalling. Each 4/20mA analog channel can be assigned to one of 44 measured parameters.

Digital Communications

RS485 Modbus RTU

Integra 2000 digital metering systems offer an RS485 communication port for direct connection to SCADA systems using the Modbus RTU protocol, or the Johnson Controls Metasys NII protocol. Remote monitoring enables the user to record the systems parameters in real time, using high resolution numbers. The Modbus protocol establishes the format for the master's query by placing it into the device address. The slave's response is also constructed using the Modbus protocol; it contains the fields confirming the action taken, the data to be returned, and an error-checking field.

Lonworks Interface

The Lonworks interface option is designed to conform to the LonMark Interoperability Guidelines version 3.2. This ensures Integra digital metering systems can be integrated into a single control network without requiring custom node or network tool development.

Measurement, Display and Communication

Integra 2000 offers configuration, display and configuration of up to 103 electrical and power quality parameters.

- 1 System Volts
System Amps
Frequency
System kW
- 2 Volts L1-N (4 wire only)
Volts L2-N (4 wire only)
Volts L3-N (4 wire only)
Volts L-N (average)
- 3 Minimum Volts L-N (per phase)
- 4 Maximum Volts L-N (per phase)
- 5 Volts L1-L2
Volts L2-L3
Volts L3-L1
Volts L-L (average)
- 6 Minimum Volts L-L (per phase)
- 7 Maximum Volts L-L (per phase)
- 8 Current L1
Current L2
Current L3
Current (average)
- 9 Minimum Current (per phase)
- 10 Maximum Current (per phase)
- 11 Current Demand
Current Maximum Demand
- 12 System Frequency
Minimum Frequency
Maximum Frequency
- 13 System Watts (sum)
System VAr (sum)
System VA (sum)
Power Factor Sys
- 14 Watts L1
Watts L2
Watts L3
Watts Sum
- 15 Minimum Watts (per phase)
- 16 Maximum Watts (per phase)
- 17 VAr L1
VAr L2
VAr L3
VAr Sum
- 18 Minimum VAr (per phase)
- 19 Maximum VAr (per phase)
- 20 VA L1
VA L2
VA L3
VA Sum
- 21 Minimum VA (per phase)
- 22 Maximum VA (per phase)
- 23 Power Factor L1
Power Factor L2
Power Factor L3
Power Factor Sys
- 24 Phase Angle L1
Phase Angle L2
Phase Angle L3
Phase Angle Sys
- 25 KW Hr Import (8 digit resolution)
KW Hr Export (8 digit resolution)
KVAr Hr Import (8 digit resolution)
KVAr Hr Export (8 digit resolution)
VA Hr (8 digit resolution)
A Hr (8 digit resolution)
- 26 KW Demand (Import)
KW Maximum Demand (Import)
KW Demand (Export)
KW Maximum Demand (Export)

Programmable Parameters

Parameter	Range
Password:	4 digit 0000 - 9999
Primary Current:	Max 999.9kA (999MW max**)
PT Primary:	999.9kV (999MW max**)
** maximum PT or CT ratios are limited so that the combination of primary voltage and current do not exceed 999MW at 120% of relevant input	
Reset:	Individual energy registers, minimum and maximum registers, demand registers
Demand Integration Time:	1 - 30 minutes
Demand Sub-intervals:	1 - 30 minutes
RS485 Interface Baud Rate:	2.4, 4.8, 9.6, 19.2 kB
RS485 Parity:	Odd, Even, None
Stop Bits:	1, 2
Modbus Address:	1 - 247
Analog Output Assignment:	Pick list of 44 measured parameters
Pulse Output Assignment:	Import KW.Hr, Export KW.Hr, Import VAr.Hr, Export VAr.Hr, VA.Hr, Amp.Hr, None
Pulse Rate Divisors:	1, 10, 100, 1000
Pulse Output Duration:	20 - 200 ms
User Screen:	4 lines, choice of 42 measured parameters
Display Update Rate (override):	1 - 20

Product Codes

Product Code	Product Configuration
244-INMW-*.**. **	Integra 2000 3 phase 3 wire, 5A CT input
Input Voltage Suffix *	
VUA2	100V L-L input, 100-250V AC/DC auxiliary
QPA2	110V L-L input, 100-250V AC/DC auxiliary
BFA2	115V L-L input, 100-250V AC/DC auxiliary
PQA2	120V L-L input, 100-250V AC/DC auxiliary
VUA5	100V L-L input, 12-48V DC auxiliary
QPA5	110V L-L input, 12-48V DC auxiliary
BFA5	115V L-L input, 12-48V DC auxiliary
PQA5	120V L-L input, 12-48V DC auxiliary

Product Code	Product Configuration
244-INWW-*.**. **	Integra 2000 3 phase 4 wire, 5A CT input
Input Voltage Suffix *	
VQA2	220V L-N input, 100-250V AC/DC auxiliary
VRA2	230V L-N input, 100-250V AC/DC auxiliary
QSA2	240V L-N input, 100-250V AC/DC auxiliary
RSA2	250V L-N input, 100-250V AC/DC auxiliary
PGA2	254V L-N input, 100-250V AC/DC auxiliary
QYA2	277V L-N input, 100-250V AC/DC auxiliary
VQA5	220V L-N input, 12-48V DC auxiliary
VRA5	230V L-N input, 12-48V DC auxiliary
QSA5	240V L-N input, 12-48V DC auxiliary
RSA5	250V L-N input, 12-48V DC auxiliary
PGA5	254V L-N input, 12-48V DC auxiliary
QYA5	277V L-N input, 12-48V DC auxiliary

Communication Options**	
000000	No outputs
4800P2	RS485 Modbus, 2 pulse relays
48A2P2	RS485, 4 x 4/20mA analog outputs, 2 pulse relays
JC00P2	RS485 Johnson Controls, 2 pulse outputs
JCA2P2	RS485 Johnson Controls, 4 x 4/20mA analog outputs, 2 pulse relays
LN0000	Lonworks interface

Order Code Example

244-INWW-VRA2-4800P2 - Integra 2000 3 phase 4 wire, input 230V L-N nominal voltage, 5A CT input, 100-250V AC/DC auxiliary, with RS485 Modbus and two pulse relay outputs.



Specification

Input	
Nominal Input Voltage:	220-277V L-N, 100-120V L-L
Max Continuous Input Voltage:	120% nominal
Max Short Duration Input Voltage:	2 x for 1 second, repeated 10 times at 10 second intervals
System PT Ratios (primary):	Any value up to 999.9 kV
Nominal Input Voltage Burden:	0.2 VA
Nominal Input Current:	5A
System CT Primary Values:	Any value up to 999.9 kA
Max Continuous Input Current:	120% nominal
Max Short Duration Current Input:	20 x for 1 sec, repeated 5 times at 5 min intervals
Nominal Input Current Burden:	0.6 VA
	** maximum PT or CT ratios are limited so that the combination of primary voltage and current do not exceed 999MW at 120% of relevant input
Outputs	
RS485 Communications:	Two wire half duplex
Baud Rates:	2400, 4800, 9600, 19200
Pulsed:	Clean contact SPNO, 100V DC 0.5A max
Pulse Duration:	20 to 200 milliseconds (20ms steps)
Pulsed Outputs:	2
Analog Outputs:	4 x 4/20mA into 500Ω (requires external DC supply, 16V-27V)
Auxiliary	
Standard Nominal Supply Voltage:	100 to 250V AC or DC
AC Supply Frequency Range:	45 – 66Hz
AC Supply Burden:	6VA
Optional Auxiliary DC Supply:	12 – 48V DC
DC Supply Burden:	6VA
Measuring Ranges	
Voltage:	10 ... 100% of nominal (functional 5..120%)
Current:	10 ... 100% of nominal (functional 5..120%)
Frequency:	45 .. 66Hz
Power Factor:	-1/0/1/0/-1 (functional 4 quadrant, 0-1 lag/lead)
Energy:	8 digit resolution
Accuracy	
Voltage:	0.5% of reading ± 4 digits
Current:	0.5% of reading ± 4 digits
Frequency:	0.1% of mid frequency ± 2 digits
Active Power:	1% of reading ± 4 digits
Power Factor:	1% of reading ± 4 digits
Reactive Power (VAr):	2% of reading ± 4 digits
Apparent Power (VA):	2% of reading ± 4 digits
Neutral Current Calculated:	4% of end scale
Energy:	1% of reading ± 4 digits
KVAr.Hr:	2% of reading ± 4 digits
Temperature Coefficient:	±0.013%/°C typical
Update Time:	Display: 1 second Optional Digital Port: 200ms
Analog Output:	1.5% of end scale
Enclosure	
Enclosure Style:	DIN 96 panel mount
Compliant With:	IEC 1010/BS EN 61010-1, IEC 664, VDE 0110, PD 6499, EMC and LVD
Material:	Polycarbonate
Terminals:	Shrouded screw clamp
Fixing:	2 corner clamps and thumb screws
Dielectric Voltage:	Withstand test 2.2kV RMS between inputs & auxiliary 1kV RMS between outputs & auxiliary
Operating Temperature:	0 to +50°C
Storage Temperature:	-20 to +65°C
Relative Humidity:	0 .. 95% non condensing
Shock:	30g in 3 planes
Vibration:	10 .. 15Hz, 1.5mm peak to peak / 15 .. 150Hz @1g
Front of Panel IP Protection:	IP54
Dimensions:	96mm high x 96mm wide x 156mm deep 3.78" wide x 3.78" wide x 6.12" deep
Panel Cut Out:	92mm x 92mm, 3.62" x 3.62"



Dimensions

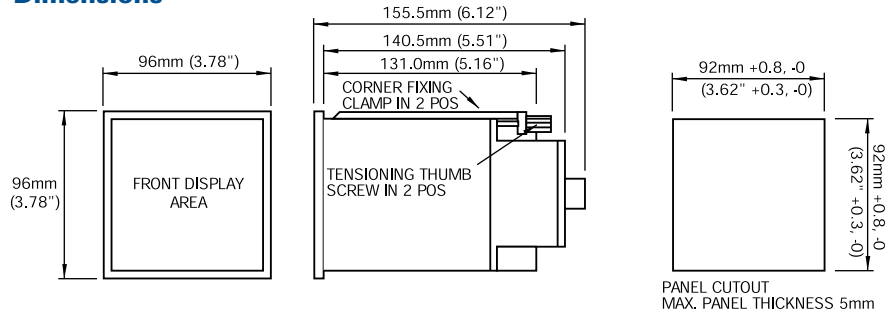

Wiring

Input connections are made directly to shrouded screw clamp terminals. Terminals for both current and voltage connections are sized to accept two #9 AWG (3mm²) solid or stranded wires. Connections for digital interface, pulsed and analog options are via screw clamp connectors. Connectors offer retained wire protection leaves suitable for one #10 AWG (2.5mm²) solid or stranded wire.

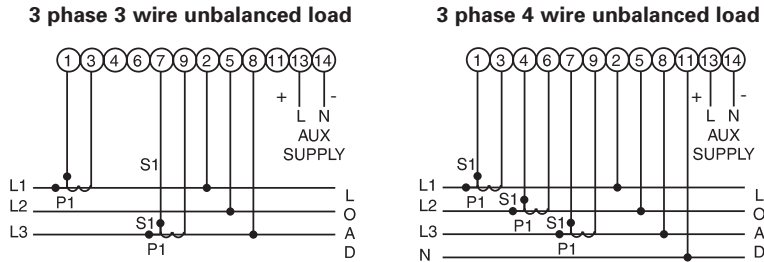

Import and Export Connections

The connection diagrams shown assume an import power configuration, therefore power factor is shown as import (IMP). Current will flow towards the load, if current flows away from the load, in an export power situation, then the power factor indication will change to export (EXP). Integra 2000 serves the full four conditions of power factor, therefore separate export connections are not required.

Auxiliary Supply

The Integra 2000 should ideally be powered from a dedicated supply, either 100 – 250V AC/DC or 12-48V. However the device may be powered from the signal source, provided the source remains within the working range of the chosen auxiliary supply.

Fusing

It is recommended that all voltage lines are fitted with 1 Amp fuses.

Safety / Ground Connections

For safety reasons, CT secondary connections should be grounded in accordance with local regulations.