

## Installation and Operating Manual Integra 1560 and 1580 Digital Metering and Transducer Systems



# **Crompton Integra Digital Transducer**

## **Installation & Operating Instructions**

**INT-1561, INT-1562, INT-1563, INT-1564,  
INT-1581, INT-1582, INT-1583 and INT-1584**

Crompton Instruments  
Freebournes Road  
Witham  
Essex  
CM8 3AH  
England

Tel: +44 (0) 1376 509 509

Fax: +44 (0) 1376 509 511

E-Mail: [crompton.info@tycoelectronics.com](mailto:crompton.info@tycoelectronics.com)

<b>Contents</b>	<b>Page</b>
<b>1 Introduction</b>	5
<b>2 Serial Communications</b>	7
2.1. Port 1 – Display, Modbus or JC N2	7
2.2. Port 2 Option – Display or Modbus	7
2.3. Display auto detect	7
2.4. Communications Parameter Set Up	7
<b>3 Modbus Implementation</b>	8
<b>4 Modbus Holding Registers and Transducer set up</b>	11
<b>5 RS485 Implementation of Johnson Controls Metasys</b>	16
<b>6 Pulsed Output Option</b>	19
<b>7 Analogue Output Option</b>	19
<b>8 Basis of measurement and calculations</b>	20
8.1. Reactive and Apparent Power	20
8.2. Energy resolution	20
8.3. Power Factor	20
8.4. Maximum Demand	21
8.5. Total Harmonic Distortion	21
<b>9 Specification</b>	22
9.1. Inputs	22
9.2. Auxiliary	22
9.3. Measuring Ranges	23
9.4. Accuracy	23
9.5. Reference conditions of influence quantities	24
9.6. Range of Use	24

<b>Contents</b>	<b>Page</b>
9.7. Standards	25
9.8. Insulation	25
9.9. Environmental	25
9.10. Enclosure	26
9.11. Serial Communications Option	26
9.12. Active Energy Pulsed Output Option	26
9.13. Analogue Outputs Option	27
<b>10 Metered Supply Connection Diagrams</b>	<b>28</b>
<b>11 Output Connections</b>	<b>30</b>
<b>12 Installation and Maintenance</b>	<b>30</b>
12.1. Introduction	30
12.2. Electromagnetic Compatibility	31
12.3. Wiring	32
Metered Supply Input	32
Additional considerations for three wire systems	32
Output	32
Optional Display	33
Relay connections	33
12.4. Auxiliary Supply	33
12.5. Maintenance	34
Case Dimension	35
INT-1560 Case Dimensions – DIN Rail Mounting	35
INT-1580 Case Dimensions – Surface Mounting	35
<b>Appendix A - CE Declaration of Conformity</b>	<b>36</b>

## 1. Introduction

The Crompton Integra 1560/1580 is a measuring and communication module available with digital, analogue or visual interfaces. Typically, it is used in conjunction with an Integra display unit. When a permanent display is not required, the display can be temporarily connected for set up and system commissioning, and then disconnected. The Integra configuration software tool running on a Windows platform may also be used for set-up. Either communications port can be connected to a display or to a Modbus master. One communications port also supports Johnson Controls NII protocol.

The Integra 1560/1580 will measure and communicate many electrical parameters, including THD values. All voltage and current measurements are True RMS for accurate measurement of non sinusoidal waveforms.

Not all configurations and options described in this manual may be immediately available. Contact your supplier for details of availability.

1560/1580 configurations and model numbers:

System	DIN Rail Mounting Model No.	Surface Mounting Model No.
Single Phase 2 Wire	INT-1562	INT-1582
Single Phase 3 Wire	INT-1561	INT-1581
3 Phase 3 Wire	INT-1563	INT-1583
3 Phase 4 Wire	INT-1564	INT-1584

The set up of the Integra 1560/1580 may be carried out by using the Crompton Integra display unit or Integra configuration software – the user documentation gives more information on :

- Configuring for use with installed current transformers
- Setting Potential Transformer / Voltage Transformer ratios, where required
- Demand Integration Time
- Resetting demand and energy
- Pulsed output set up
- Communications (RS485) set up
- Analogue output set up
- Password protection of set up screens to prevent accidental modification

If required, most set up parameters may be manipulated directly via the Modbus interface.

**Important safety information is contained in the Installation and Maintenance section. Users must familiarise themselves with this information before attempting installation or other procedures.**

The parameters available from this Digital Transducer are listed in the table below.

Measured Quantity (Where applicable)	Units of measurement
Voltage - Average, L1-L2, L2-L3, L3-L1, L1-N, L2-N & L3-N	Volts
Current - Average & Individual Phases	Amps
Total Voltage Harmonic Distortion - Average & Individual Phases	% of Total RMS
Total Current Harmonic Distortion - Average & Individual Phases	% of Total RMS
Neutral Current	Amps
Frequency - System	Hz
Power Factor - Average & Individual Phases	
Power Factor - Inductive or Capacitive	C or L
Phase Angle - Average & Individual Phases	Degrees
Active Power - Sum & Individual Phases	kW
Reactive Power - Sum & Individual Phases	kVar
Apparent Power - Sum & Individual Phases	kVA
Active Energy - System	kWh
Reactive Energy - System	kvarh
Current Demand - Total	Amps dmd
Active Power Demand - Total	kW dmd
Maximum Current Demand - Total	Amps dmd
Maximum Active Power Demand - Total	kW dmd

Interfaces include:

- Display or RS485 Modbus RTU Port (standard)
- Second Modbus or Display Port (optional)
- One or two Energy Pulse Relays representing kWh and kvarh (optional)
- One Analogue Output Channel (optional)
- Second Analogue Output Channel (optional)

Connections for all interfaces are via detachable two-part screw clamp connectors.

## 2. Serial Communications

### 2.1. Port 1 – Display, Modbus or JC N2

All Integra 1560/1580 digital transducers have fitted as standard one communications port. This port can be used for either the Integra display unit, as an RS485 Modbus RTU port, or as a Johnson Controls N2 protocol slave. Choice of reply protocol is made by the Integra on the basis of the format of request, so that a Modbus request receives a Modbus reply, and an N2 protocol request receives an N2 protocol reply.

### 2.2. Port 2 Option – Display or Modbus

Integra 1560/1580 digital transducers can have an optional second communications port. This port can be used for either the Integra display unit or as an RS485 Modbus RTU port.

With the exception of JC N2 support, port 2 functions in the same way as port 1

### 2.3. Display auto detect

On power up the Integra 1560 and 1580 have a Display Auto Detect facility. For about five seconds the instrument will attempt to determine if a display is attached to a port. If it detects an Integra display unit is powered up and attached, the communication settings on that port will be fixed to display operation until the instrument is powered down.

If the display auto detect period expires without a display unit being detected, the Integra 1560/1580 will configure the port to use the communication parameters previously set for that port. If a display is subsequently connected to the port, it will generally not function correctly. Power cycle the Integra 1560/1580 to restore display correct operation. As recommended in the installation section, ideally the transducer and any associated displays should share a common auxiliary supply so that the auto detect mechanism can function properly. If this is not possible, then either the display auxiliary should start first, or the communications parameters for a port that is to be connected to a display should be user set to 9600 baud, two stop bits, no parity.

### 2.4. Communications Parameter Set Up

If communications parameter options (baud rate, stop bits, parity, address) are set from an Integra display unit, the transducer modifies the communications settings of the other port. For example, any communications settings changes made on a display plugged into port 1 will affect port 2 only.

Communications parameter options set from the configuration program or another Modbus master affect the port on which the Modbus master is connected. Changes take effect only when the transducer is power cycled. For example, if the baud rate is currently set to 9600 baud and is then changed to 4800 baud, by a Modbus master on port 1, the acknowledgement and any subsequent communications are at 9600 baud. After the transducer has been power cycled, communications on port 1 will be at 4800 baud. Communications parameters may be checked by connecting an Integra display to Port 2. Caution should be exercised with a single port transducer, as "lost" communications settings can only be recovered by trial and error, or return to factory.

### 3. Modbus® Implementation

This section provides basic information for the integration of the product to a Modbus network. If background information or more details of the Integra implementation is required please refer to our "Guide to RS485 Communications and the Modbus Protocol", available on our CD catalogue or from any recognised supplier.

Integra 1560/1580 offers the option of a RS485 communication facility for direct connection to SCADA systems using the Modbus, RTU protocol. The Modbus, protocol establishes the format for the master's query by placing into it the device address, a function code defining the requested action, any data to be sent, and an error checking field. The slave's response message is also constructed using Modbus protocol. It contains fields confirming the action taken, any data to be returned, and an error-checking field. If an error occurs in receipt of the message, or if the slave is unable to perform the requested action, the slave will construct an error message and send it as it's response.

The electrical interface is 2-wire RS485, via 3 screw terminals. Connection should be made using twisted pair screened cable (Typically 22 gauge Belden 8761 or equivalent). All "A" and "B" connections are daisy chained together. The screens should also be connected to the "Gnd" terminal. To avoid the possibility of loop currents, an Earth connection should be made at only one point on the network.

Line topology may or may not require terminating loads depending on the type and length of cable used. Loop (ring) topology does not require any termination load.

The impedance of the termination load should match the impedance of the cable and be at both ends of the line. The cable should be terminated at each end with a 120 ohm (0.25 Watt min.) resistor.

A total maximum length of 3900 feet (1200 metres) is allowed for the RS485 network. A maximum of 32 electrical nodes can be connected, including the controller.

The address of each Integra 1560/1580 can be set to any value between 1 and 247. Broadcast mode (address 0) is not supported.

The maximum latency time of an Integra 1560/1580 is 150ms i.e. this is the amount of time that can pass before the first response character is output. The supervisory programme must allow this period of time to elapse before assuming that the Integra 1560/1580 is not going to respond.

The format for each byte in RTU mode is:

Coding System:           8-bit per byte

Data Format:               4 bytes (2 registers) per parameter.

Floating point format ( to IEEE 754)

Most significant register first (Default). The default may be changed if required - See Holding Register "Register Order" parameter.

Error Check Field: 2 byte Cyclical Redundancy Check (CRC)

Framing: 1 start bit  
 8 data bits, least significant bit sent first  
 1 bit for even/odd parity or no parity  
 1 stop bit if parity is used; 1 or 2 bits if no parity

Data Transmission speed is selectable between 2400, 4800, 9600 and 19200 baud.

### Input Registers

Input registers are used to indicate the present values of the measured and calculated electrical quantities.

Each parameter is held in two consecutive 16 bit registers. The following table details the 3X register address, and the values of the address bytes within the message. A tick (±) in the column indicates that the parameter is valid for the particular wiring system. Any parameter with a cross (X) will return the value Zero (0000h).

Each parameter is held in the 3X registers. Modbus Function Code 04 is used to access all parameters.

e.g. to request

Volts 1 Start address	= 00
No of registers	= 02
Volts 2 Start address	= 02
No of registers	= 02

Each request for data must be restricted to 40 parameters or less. Exceeding the 40 parameter limit will cause a Modbus exception code to be returned.

Address (Register)	Parameter Number	Parameter	Modbus Start Address Hex		3 Ø	3 Ø	1 Ø	1 Ø
			High Byte	Low Byte	4 wire	3 wire	3 wire	2 wire
30001	1	Volts 1 (L1 – N 4W or L1 – L2 3W)	00	00	✓	✓	✓	✓
30003	2	Volts 2 (L2 – N 4W or L2 – L3 3W)	00	02	✓	✓	✓	X
30005	3	Volts 3 (L3 – N 4W or L3 – L1 3W)	00	04	✓	✓	X	X
30007	4	Current 1	00	06	✓	✓	✓	✓
30009	5	Current 2	00	08	✓	✓	✓	X
30011	6	Current 3	00	0A	✓	✓	X	X
30013	7	W Phase 1	00	0C	✓	X	✓	✓
30015	8	W Phase 2	00	0E	✓	X	✓	X
30017	9	W Phase 3	00	10	✓	X	X	X
30019	10	VA Phase 1	00	12	✓	X	✓	✓
30021	11	VA Phase 2	00	14	✓	X	✓	X
30023	12	VA Phase 3	00	16	✓	X	X	X
30025	13	var Phase 1	00	18	✓	X	✓	✓
30027	14	var Phase 2	00	1A	✓	X	✓	X
30029	15	var Phase 3	00	1C	✓	X	X	X
30031	16	Power Factor Phase 1	00	1E	✓	X	✓	✓
30033	17	Power Factor Phase 2	00	20	✓	X	✓	X
30035	18	Power Factor Phase 3	00	22	✓	X	X	X
30037	19	Phase Angle Phase 1	00	24	✓	X	✓	✓
30039	20	Phase Angle Phase 2	00	26	✓	X	✓	X
30041	21	Phase Angle Phase 3	00	28	✓	X	X	X
30043	22	Volts Ave	00	2A	✓	✓	✓	✓
30047	24	Current Ave	00	2E	✓	✓	✓	✓
30049	25	Current Sum	00	30	✓	✓	✓	✓
30053	27	Watts Sum	00	34	✓	✓	✓	✓
30057	29	VA Sum	00	38	✓	✓	✓	✓
30061	31	var Sum	00	3C	✓	✓	✓	✓
30063	32	Power Factor Ave	00	3E	✓	✓	✓	✓
30067	34	Average Phase Angle	00	42	✓	✓	✓	✓
30071	36	Frequency	00	46	✓	✓	✓	✓
30073	37	Wh Import	00	48	✓	✓	✓	✓
30077	39	varh Import	00	4C	✓	✓	✓	✓
30085	43	W Demand Import	00	54	✓	✓	✓	✓
30087	44	W Max. Demand Import	00	56	✓	✓	✓	✓
30105	53	A Demand	00	68	✓	✓	✓	✓
30107	54	A Max. Demand	00	6A	✓	✓	✓	✓
30201	101	V L1-L2 (calculated)	00	C8	✓	X	✓	X
30203	102	V L2-L3 (calculated)	00	CA	✓	X	X	X
30205	103	V L3-L1 (calculated)	00	CC	✓	X	X	X
30207	104	Average Line to Line Volts	00	CE	✓	X	✓	X
30225	113	Neutral Current	00	E0	✓	X	✓	✓
30235	118	THD Volts 1	00	EA	✓	✓	✓	✓
30237	119	THD Volts 2	00	EC	✓	✓	✓	X
30239	120	THD Volts 3	00	EE	✓	✓	X	X
30241	121	THD Current 1	00	F0	✓	✓	✓	✓
30243	122	THD Current 2	00	F2	✓	✓	✓	X
30245	123	THD Current 3	00	F4	✓	✓	X	X
30249	125	THD Voltage Mean	00	F8	✓	✓	✓	✓
30251	126	THD Current Mean	00	FA	✓	✓	✓	✓
30255	128	Power Factor (+Ind/-Cap)	00	FE	✓	✓	✓	✓

## 4. Modbus Holding Registers and Transducer set up

Holding registers are used to store and display instrument configuration settings. All holding registers not listed in the table below should be considered as reserved for manufacturer use and no attempt should be made to modify their values.

The demand parameters may be viewed or changed using the Modbus protocol. Each parameter is held in the 4X registers. Modbus Function Code 03 is used to read the parameter and Function Code 16 is used to write.

Address (Register)	Parameter Number	Parameter	Modbus Start Address Hex		Valid range	Mode
			High Byte	Low Byte		
40001	1	Demand Time	00	00	0 only	r/w
40003	2	Demand Period	00	02	8,15,20,30 minutes.	r/w
40007	4	System Voltage	00	06	1V - 400kV	r/wp
40009	5	System Current	00	08	1-9999 A	r/wp
40011	6	System Type	00	0A		ro
40013	7	Relay Pulse Width	00	0C	3,5,10 (x20mS)	r/w
40015	8	Energy Reset	00	0E	0 only	wo
40019	10	RS485 set-up code *	00	12	See table below	r/w
40021	11	Node Address	00	14	1-247	r/w
40023	12	Pulse Divisor	00	16	1,10,100,1000	r/w
40025	13	Password	00	18	0000-9999	r/w
40037	19	System Power	00	24		r/o
40041	21	Register Order	00	28	2141.0 only	wo
40299	150	Secondary Volts	01	2A	Min Vin-Max Vin	r/wp
40307	154	Max Energy Count	01	32	6,7,8 digits	r/wp
40309	155	Analogue Hardware Max	01	34		ro
40311	156	Analogue Hardware Min	01	36		ro
40313	157	Analogue 1 Output Parameter	01	38	See table below	r/wp
40315	158	Analogue 1 Parameter Max	01	3A		ro
40317	159	Analogue 1 Parameter Min	01	3C		ro
40319	160	Analogue 1 Reading Top	01	3E	Analogue 1 Parameter Max	r/wp
40321	161	Analogue 1 Reading Bottom	01	40	Analogue 1 Parameter Min	r/wp
40323	162	Analogue 1 Output Top	01	42	Analogue Hardware Max	r/wp
40325	163	Analogue 1 Output Bottom	01	44	Analogue Hardware Min	r/wp
40329	165	Analogue 2 Output Parameter	01	48	See table below	r/wp
40331	166	Analogue 2 Parameter Max	01	4A		ro
40333	167	Analogue 2 Parameter Min	01	4C		ro
40335	168	Analogue 2 Reading Top	01	4E	Analogue 2 Parameter Max	r/wp
40337	169	Analogue 2 Reading Bottom	01	50	Analogue 2 Parameter Min	r/wp
40339	170	Analogue 2 Output Top	01	52	Analogue Hardware Max	r/wp
40341	171	Analogue 2 Output Bottom	01	54	Analogue Hardware Min	r/wp

r/w = read/write r/wp = read and write with password clearance ro = read only wo = write only

**Password Settings** marked r/wp require the instrument password to have been entered into the Password register before changes will be accepted. Once the instrument configuration has been modified, the password should be written to the password register again to protect the configuration from unauthorised or accidental change. Power cycling also restores protection. Reading the Password register returns 1 if the instrument is unprotected and 0 if it is protected from changes.

**Demand Time** is used to reset the demand period. A value of zero must be written to this register to accomplish this. Writing any other value will cause an error to be returned. Reading this register after instrument restart or resetting demand period gives the number of minutes of demand data up to a maximum of the demand period setting. For example, with 15 minute demand period, from reset the value will increment from zero every minute until it reaches 15. It will remain at this value until a subsequent reset occurs.

**Demand Period** The value written must be one of 8,15, 20 or 30, representing demand time in minutes. Writing any other value will cause an error to be returned.

**System Voltage** in a PT/VT connected system is the PT/VT primary voltage. In a direct connected (i.e. no PT.VT) system this parameter should be set the same as secondary volts.

**System Current** is the CT primary current.

**System Type** The System type address will display '1' for single phase 2 wire, '2' for 3 Phase 3 Wire, '3' for 3 Phase 4 Wire or 4 for single phase 3 wire.

**Relay Pulse Width** is the width of the relay pulse in multiples of 20 ms. However, only values of 3 (60 ms), 5 (100 ms) or 10 (200 ms) are supported. Writing any other value will cause an error to be returned.

**Reset Energy** is used to reset the Energy readings. A value of zero must be written to this register to accomplish this. Writing any other value will cause an error to be returned.

**RS485 Set-Up Code**

Baud Rate	Parity	Stop Bits	Decimal Value
19200	NONE	2	30
19200	NONE	1	14
19200	ODD	1	13
19200	EVEN	1	12
9600	NONE	2	26
9600	NONE	1	10
9600	ODD	1	9
9600	EVEN	1	8
4800	NONE	2	22
4800	NONE	1	6
4800	ODD	1	5
4800	EVEN	1	4
2400	NONE	2	18
2400	NONE	1	2
2400	ODD	1	1
2400	EVEN	1	0



Codes not listed in the table may give rise to unpredictable results including loss of communication. Exercise caution when attempting to change mode via direct Modbus writes. Use of a display or the configuration program is recommended.

**Node Address** is the Modbus or JC N2 slave address for the instrument. Any value between 1 and 247 can be set.

**Pulse Rate Divisor**, only values of 1,10,100 or 1000 are supported. Writing any other value will cause an error to be returned.

**System Power**, the maximum system power based on the values of system type, system volts and system current.

**Register Order**, the instrument can receive or send floating-point numbers in normal or reversed register order. In normal mode, the two registers that make up a floating point number are sent most significant bytes first. In reversed register mode, the two registers that make up a floating point number are sent least significant bytes first. To set the mode, write the value '2141.0' into this register - the instrument will detect the order used to send this value and set that order for all Modbus transactions involving floating point numbers.

**Secondary Volts** indicates the voltage on the VT secondary when the voltage on the Primary is equal to the value of System Volts . The value of this register can be set to between the minimum and maximum instrument input voltage.

**Maximum Energy Count**, this controls the number of digits the energy (kWh and kvarh) counters can use before they roll over (i.e. resets to zero). The values of 6, 7 or 8 can be written to this register to indicate the number of digits to use. Other values will be rejected.

**Analogue Hardware Minimum** and **Analogue Hardware Maximum** indicate respectively the minimum and maximum output currents that the instrument analogue output hardware is capable of.

**Analogue 1 Output Parameter**, the number of the input parameter that is to be output on analogue output 1. A value of zero signifies the analogue output is unused.

**Analogue 1 Parameter Maximum**, the maximum value that the selected input parameter can reach.

**Analogue 1 Parameter Minimum**, the minimum value that the selected input parameter can reach.

**Analogue 1 Reading Top**, the upper limit of the parameter value that will be output. This value can range between Parameter Minimum and Parameter Maximum.

**Analogue 1 Reading Bottom**, the lower limit of the parameter value that will be output. This value can range between Parameter Minimum and Parameter Maximum.

**Analogue 1 Output Top**, the analogue output level that will be achieved when the parameter reading reaches Reading Top. The value of Output Top must be between Analogue Hardware Minimum and Analogue Hardware Maximum.

**Analogue 1 Output Bottom**, the analogue output level that will be achieved when the parameter reading reaches Reading Bottom. The value of Output Bottom must be between Analogue Hardware Minimum and Analogue Hardware Maximum.



**Analogue 2** set up values function in the same way as Analogue 1, except of course, they refer to the second analogue channel.

Note: Analogue Hardware Maximum and Minimum refer to the factory build hardware limits. It is the same for all analogue channels on a particular instrument.

### **Analogue Output Operation**

When the values of Output Top is greater than Output Bottom, the analogue output will operate in a non-inverting mode. That is, when the selected metered value increases the analogue output will increase.

When the value of Output Top is less than Output Bottom, the analogue output will operate in inverting mode. That is, as the selected metered value increases the analogue output will decrease. This can also be achieved by reversing Reading Top and Reading Bottom values. Reversing both will self cancel.

When the value of Reading Top is equal to Reading Bottom, the analogue output will operate in Threshold mode, the threshold being the value of Reading Top and Bottom. When the selected metered value rises above the threshold the analogue output will switch to Output Top. When the selected metered value falls below the threshold the analogue output will switch to Output Bottom.

When Output Top is set to the same value as Output Bottom the analogue output will be fixed at the specified value, effectively turning the output into a constant current generator.

The following parameters may be selected to be represented as analogue outputs. The ranges shown are the limit values for Reading Top and Reading Bottom.

Parameter		System Type			
No.	Name	3 Ø 4 wire	3 Ø 3 wire	1 Ø 3 wire	1 Ø 2 wire
1	Volts 1	0 – 1.2 * Vs	0 – 1.2 * Vs	0 – 1.2 * Vs	
2	Volts 2	0 – 1.2 * Vs	0 – 1.2 * Vs		
3	Volts 3	0 – 1.2 * Vs			
4	Current 1	0 – 1.2 * Is	0 – 1.2 * Is	0 – 1.2 * Is	
5	Current 2	0 – 1.2 * Is	0 – 1.2 * Is		
6	Current 3	0 – 1.2 * Is			
7	W 1	± 1.44 * Vs * Is		± 1.44 * Vs * Is	± 1.44 * Vs * Is
8	W 2	± 1.44 * Vs * Is		± 1.44 * Vs * Is	
9	W 3	± 1.44 * Vs * Is			
10	VA 1	0 – 1.44 * Vs * Is		0 – 1.44 * Vs * Is	0 – 1.44 * Vs * Is
11	VA 2	0 – 1.44 * Vs * Is		0 – 1.44 * Vs * Is	
12	VA 3	0 – 1.44 * Vs * Is			
13	var 1	± 1.44 * Vs * Is		± 1.44 * Vs * Is	± 1.44 * Vs * Is
14	var 2	± 1.44 * Vs * Is		± 1.44 * Vs * Is	
15	var 3	± 1.44 * Vs * Is			
16	Power Factor 1	± 1		± 1	± 1
17	Power Factor 2	± 1		± 1	
18	Power Factor 3	± 1			
19	Phase Angle 1 deg.	± 180		± 180	± 180
20	Phase Angle 2 deg.	± 180		± 180	
21	Phase Angle 3 deg.	± 180			
22	Voltage (Average)	0 – 1.2 * Vs	0 – 1.2 * Vs	0 – 1.2 * Vs	0 – 1.2 * Vs
24	Current (Average)	0 – 1.2 * Is0 – 1.2 * Is	0 – 1.2 * Is	0 – 1.2 * Is	
25	Current (Sum)	0 – 3.6 * Is0 – 3.6 * Is	0 – 2.4 * Is	0 – 1.2 * Is	
27	W (Sum)	± 4.32 * Vs * Is	± 1.44 * ÷3 * Vs * Is	Is ± 2.88 * Vs * Is	± 1.44 * Vs * Is
29	VA (Sum)	0 – 4.32 * Vs * Is	0 – 1.44 * ÷3 * Vs * Is	Is0 – 2.88 * Vs * Is	0 – 1.44 * Vs * Is
31	var (Sum)	± 4.32 * Vs * Is	± 1.44 * ÷3 * Vs * Is	Is ± 2.88 * Vs * Is	± 1.44 * Vs * Is
32	Power Factor (Average)	± 1	± 1	± 1	± 1
34	Phase Angle (Avg) deg.	± 180	± 180	± 180	± 180
36	Frequency Hz	40 – 70	40 – 70	0 – 70	40 – 70
43	Import Power Demand	0 – 4.32 * Vs * Is	0 – 1.44 * ÷3 * Vs * Is	Is0 – 2.88 * Vs * Is	0 – 1.44 * Vs * Is
44	Import Power Max. Dem.	0 – 4.32 * Vs * Is	0 – 1.44 * ÷3 * Vs * Is	Is0 – 2.88 * Vs * Is	0 – 1.44 * Vs * Is
53	Current Demand	0 – 3.6 * Is0 – 3.6 * Is	0 – 2.4 * Is	0 – 1.2 * Is	
54	Current Max. Demand	0 – 3.6 * Is0 – 3.6 * Is	0 – 2.4 * Is	0 – 1.2 * Is	
101	Volts L1-L2	0 – 1.2 * ÷3 * Vs		0 – 2.4 * Vs	
102	Volts L2-L3	0 – 1.2 * ÷3 * Vs			
103	Volts L3-L1	0 – 1.2 * ÷3 * Vs			
104	Volts Line-Line (Avg)	0 – 1.2 * ÷3 * Vs		0 – 2.4 * Vs	
113	Neutral Current0 – 1.2 * Is		0 – 1.2 * Is	0 – 1.2 * Is	
118	THD Va %	0 – 100	0 – 100	0 – 100	0 – 100
119	THD Vb %	0 – 100	0 – 100	0 – 100	
120	THD Vc %	0 – 100	0 – 100		
121	THD Ia %	0 – 100	0 – 100	0 – 100	0 – 100
122	THD Ib %	0 – 100	0 – 100	0 – 100	
123	THD Ic %	0 – 100	0 – 100		
125	THD Voltage (Avg) %	0 – 100	0 – 100	0 – 100	0 – 100
126	THD Current (Avg) %	0 – 100	0 – 100	0 – 100	0 – 100

Vs = System Volts, Is = System Current.

When analogue outputs are used to represent either individual or average power factor, parameters have slightly different meanings.

- The sign of the power factor when defining reading top and reading bottom is the sign of the active power : +ve for active power (watts) import and -ve for active power (watts) export.
- The reading span which the analogue output represents always includes unity (active power import, zero vars), but subject to this, the range span may be set as desired, using Reading Top and Reading Bottom.
- Reading Top value sets the limit value in the "export var" quadrants
- Reading Bottom value sets the limit value in the "import var" quadrants
- The direction the output moves depends on the Output Top and Output Bottom values.
- If Output Top is greater than Output Bottom, then the analogue output value increases as the power factor moves from the "export var" quadrants to the "import var" quadrants. This is the convention normally adopted in European technically influenced areas of the world.
- If Output Top is less than Output Bottom, then the analogue output value decreases as the power factor moves from the "export var" quadrants to the "import var" quadrants. This is the convention normally adopted in North American technically influenced areas of the world.

## 5. RS485 Implementation of Johnson Controls Metasys

Johnson Controls protocol implementation is only available on Port 1. Port 2 does not support this protocol. In a JC N2 protocol installation, typically port 2, where fitted, is used for interfacing a display unit.

These notes explain Metasys and Crompton Instruments Integra 1560/1580 integration. Use these notes with the Metasys Technical Manual, which provides information on installing and commissioning Metasys N2 Vendor devices.

### Application details

The Integra 1560/1580 is a N2 Vendor device that connects directly with the Metasys N2 Bus. This implementation assigns 33 key electrical parameters to ADF points, each with override capability.

Components requirements

- Integra 1560/1580 with RS485 card and Port 1 available.
- N2 Bus cable.

### Metasys release requirements

- Metasys OWS software release 7.0 or higher.
- Metasys NCM311. NCM360.

### **Support for Metasys Integration**

Johnson Control Systems  
System House, Randalls Research Park,  
Randalls Way, Leatherhead,  
Surrey, KT22 7TS  
England

### **Support for Crompton Integra operation**

This is available via local sales and service centre.

### **Design considerations**

When integrating the Crompton equipment into a Metasys Network, keep the following considerations in mind.

- Make sure all Crompton equipment is set up, started and running properly before attempting to integrate with the Metasys Network.
- A maximum of 32 devices can be connected to any one NCM N2 Bus.

**Vendor Address** 1-247 (Limited by co-resident Modbus protocol)

#### **Port Set-up**

<b>Baud Rate</b>	9600
<b>Duplex</b>	Full
<b>Word Length</b>	8
<b>Stop Bits</b>	1
<b>Parity</b>	None
<b>Interface</b>	RS485

## METASYS N2 application

### Integra 1560/1580 Point Mapping table

Address	Parameter Description	Units
1	Voltage 1	Volts
2	Voltage 2	Volts
3	Voltage 3	Volts
4	Current 1	Amps
5	Current 2	Amps
6	Current 3	Amps
7	Voltage average	Volts
8	Current average	Amps
9	Power (Watts) Sum	Kwatts
10	VA Sum	kVA
11	var Sum	kvar
12	Power Factor average	
13	Frequency	Hz
14	Active Energy (Import)	kWh
15	Reactive Energy (Import)	kvarh
16	Watts Demand (Import)	kWatts
17	Maximum Watts Demand (Import)	kWatts
18	Amps Demand	Amps
19	Maximum Amps Demand	Amps
20	Voltage L1-L2 (calculated)	Volts
21	Voltage L2-L3 (calculated)	Volts
22	Voltage L3-L1 (calculated)	Volts
23	Neutral Current	Amps
24	Active Energy (Import)	GWh
25	Reactive Energy (Import)	Gvarh
26	THD V1	%
27	THD V2	%
28	THD V3	%
29	THD I1	%
30	THD I2	%
31	THD I3	%
32	THD Vmean	%
33	THD Imean	%

## 6. Pulsed Output Option

One or two pulsed outputs are optionally available.

These relays output pulses at a rate proportional to the measured Active import Energy (kWh) and Reactive import Energy (kvarh).

The pulse width and pulse rate are both user definable via the Integra 1540 Display module or configuration program. See the relevant manual or Modbus Holding Register section of this document for details.

The output relays provide fully isolated, volt free contacts and connection is made via screw clamp terminals.

## 7. Analogue Output Option

This module optionally provides one or two d.c. isolated outputs. These outputs can be individually assigned to represent any one of the measured and displayed continuously variable parameters.

Output range limits are factory set as one of the options in the table below. The mA range for both channels is the same.

Range	Load	Compliance Voltage
0/1mA	0-10kΩ	10V
0/5mA	0-2kΩ	10V
0/10mA	200W-1kΩ	10V
-1/0/+1mA	0-10kΩ	10V
-5/0/+5mA	0-2kΩ	10V

Parameters can be adjusted to suit the application and are not fixed to the system value. Top and bottom readings can be adjusted and a variety of outputs achieved, for example:

- Normal zero e.g. 0/1mA = 0/100kW
- Inverse zero e.g. 1mA/0 = 0/100kW
- Offset zero 0/1mA = 50/100kW
- Live zero 4-20mA = 0-100kW or 4-12-20mA = -100/0/+100kW
- Bipolar outputs, e.g. -1/0/+1mA = -100/0/+100kW

Example

Mode	0kW	50kW	100kW
Normal	0mA	0.5mA	1mA
Inverse	1mA	0.5mA	0
Offset	0	0	1mA
Live	4mA	12mA	20mA

More details of analogue output set-up are contained in the Integra 1540 Display module and configuration program user guides. These documents also cover the configuration of analogue outputs to represent power factor or phase angle, where special considerations apply.

## 8. Basis of measurement and calculations

### 8.1. Reactive and Apparent Power

Active powers are calculated directly by multiplication of voltage and current. Reactive powers are calculated using frequency corrected quarter phase time delay method. Apparent power is calculated as the square root of sum of squares of active and reactive powers. Individual phases whose apparent power is less than 3% of nominal are not included in system apparent power determinations.

### 8.2. Energy resolution

Cumulative energy counts are reported using the standard IEEE floating point format. Reported energy values in excess of 16MWh may show a small non cumulative error due to the limitations of the number format. Internally the count is maintained with greater precision. The reporting error is less than 1 part per million and will be automatically corrected when the count increases.

### 8.3. Power Factor

The magnitude of Per Phase Power Factor is derived from the per phase active power and per phase reactive power. The power factor value sign is set to negative for an inductive load and positive for a capacitive load.

The magnitude of the System Power Factor is derived from the sum of the per phase active power and per phase reactive power. Individual phases whose apparent power is less than 2% of nominal are not included in power factor determinations. The system power factor value sign is set to negative for an inductive load and positive for a capacitive load. The load type, capacitive or inductive, is determined from the signs of the sums of the relevant active powers and reactive powers. If both signs are the same, then the load is inductive, if the signs are different then the load is capacitive.

The magnitude of the phase angle is the ArcCos of the power factor. It's sign is taken as the opposite of the var's sign.

#### 8.4. Maximum Demand

The maximum power consumption of an installation is an important measurement as power utilities often levy related charges. Many utilities use a thermal maximum demand indicator (MDI) to measure this peak power consumption. An MDI averages the power consumed over a number of minutes, such that short surges do not give an artificially high reading.

Integra 1560/1580 uses a sliding window algorithm to simulate the characteristics of a thermal MDI instrument, with the demand period being updated every minute.

The demand period can be reset, which allows synchronisation to other equipment. When it is reset, the values in the Demand and Maximum Demand registers are set to zero.

Time Integration Periods can be set to 8, 15, 20 or 30 minutes

Note: During the initial period when the “sliding window” does not yet contain a full set of readings (i.e. the elapsed time since the demands were last reset or the elapsed time since Integra 1560/1580 was switched on is less than the selected demand period) then maximum demands may not be true due to the absence of immediate historical data.

The Time Integration Period can be user set either by using the Integra 1540 Display module or by using the communications option.

#### 8.5. Total Harmonic Distortion

The calculation used for the Total Harmonic Distortion is:

$$THD = ((RMS \text{ of total waveform} - RMS \text{ of fundamental}) / RMS \text{ of total waveform}) \times 100$$

This is often referred to as THD – R

The figure is limited to the range 0 to 100% and is subject to the 'range of use' limits. The instrument may give erratic or incorrect readings where the THD is very high and the fundamental is essentially suppressed.

For low signal levels the noise contributions from the signal may represent a significant portion of the “RMS of total waveform” and may thus generate unexpectedly high values of THD. To avoid indicating large figures of THD for low signal levels the product will produce a display of 0 (zero). Typically, display of THD will only produce the 0 (zero) value when the THD calculation has been suppressed due to a low signal level being detected.

It should also be noted that spurious signals (for example, switching spikes) if coincident with the waveform sampling period will be included in the “RMS of the total waveform” and will be used in the calculation of THD. The display of THD may be seen to fluctuate under these conditions.

## 9. Specification

### 9.1. Inputs

Nominal rated input voltage

	<b>Voltage range L</b>	<b>Voltage range M</b>
Single phase two wire	57 - 139V L-N	140 - 277V L-N
Single phase three wire	57 - 139V L-N (114 - 278V L-L)	140 - 240V L-N (279 - 480V L-L)
Three phase three wire	100 - 240V L-L	241 - 480V L-L
Three phase four wire	100 - 240V L-L (57 - 139V L-N)	241 - 480V L-L (140 - 277V L-N)

Voltages above are expressed as RMS values and relate to sinusoidal waveforms and corresponding instantaneous peak values. "Range Maximum" for a particular instrument refers to the upper end of the relevant voltage range.

Max continuous input voltage	120% of range maximum.
Max short duration input voltage	2* range maximum (1s application repeated 10 times at 10s intervals)
Nominal input voltage burden	0.2VA approx. per phase
Nominal input current	1 or 5A a.c. rms
System CT primary values	Std. values up to 9999A (1 or 5 Amp secondaries)
System VT ratios	Any value up to 400kV(subject to an overall power limit of 250 MW nominal, 360MW maximum and the 4 significant digit limitation of the display unit, where this is used for setup)
Max continuous input current	120% of nominal
Max short duration current input	20* nominal (1s application repeated 5 times at 5 min intervals)
Nominal input current burden	0.6VA approx. per phase

### 9.2. Auxiliary

Standard supply voltage	100 - 250V AC nominal $\pm 15\%$ (85 - 287V AC absolute limits) or 100V to 250V DC nominal +25%, -15%(85 - 312V DC absolute limits)
a.c. supply frequency range	45 to 66 Hz
a.c. supply burden	3W / 6VA
Optional auxiliary d.c.supply	12 - 48V DC. nominal +25%, -15%(10.2 – 60VDC absolute limits)
d.c. supply burden	3W / 6 VA

### 9.3. Measuring Ranges

Values of measured quantities for which accuracy is defined.

Voltage	80 .. 120% of nominal (any voltage within the specified range – eg 45.6V to 166.8V L-N 4 wire L range)
Current	5 .. 120% of nominal
Frequency	45 .. 66 Hz
Active power (Watt)	5 .. 120% of nominal, bi-directional, 360 MW Max
Reactive power (var)	5 .. 120% of nominal, bi-directional, 360 Mvar Max
Apparent power (VA)	5 .. 120% of nominal, 360 MVA Max
Power Factor	0.8 lagging .. 1 .. 0.8 leading,
Total Harmonic Distortion	Up to 31st Harmonic 0%-40%, with typical harmonic content distribution, defined to be less than 15% of fundamental amplitude in harmonics content above 15th

Voltage and current ranges assume that crest values are less than 168% of rms nominal.

### 9.4. Accuracy

Voltage	0.17 % of Range Maximum
Current	0.17 % of nominal
Neutral current (calculated)	0.95 % of nominal
Frequency	0.15% of mid frequency
Power factor	1% of Unity (0.01)
Active power (W)	±0.2 % of Range Maximum
Reactive power (var)	±0.5 % of Range Maximum
Apparent power (VA)	±0.2% of Range Maximum
Active energy (W.h)	0.3% of Range Maximum* Exceeds class 1 IEC1036 Section 4.6
Reactive energy (var.h)	0.6% of Range Maximum*
Total Harmonic Distortion	1%, up to 31st harmonic
Temperature coefficient	0.013%/°C V,I typical 0.018% W, var, VA typical
Response time to step input	0.35 seconds plus Modbus response time (to >99% of final value, at 50Hz. 60Hz response time is faster)

Error change due to variation of an influence quantity in the manner described in section 6 of IEC688:1992

2 \* Error allowed for the reference condition applied in the test. Error due to temperature variation as above.

Error in measurement when a measurand is within its measuring range, but outside its reference range.

2 \* Error allowed at the end of the reference range adjacent to the section of the measuring range where the measurand is currently operating / being tested.

\*Error in energy readings is expressed as a percentage of the energy count that would result from applying range maximum voltage and nominal current for the same measurement period.

**9.5. Reference conditions of influence quantities**

Influence quantities are variables which affect measurement errors to a minor degree. Accuracy is verified under nominal value (within the specified tolerance) of these conditions.

Ambient temperature	23°±1°C
Input frequency	50 or 60 Hz ±2%
Input waveform	Sinusoidal (distortion factor < 0.005)
Auxiliary supply voltage	Nominal ±1%
Auxiliary supply frequency	Nominal ±1%
Auxiliary supply (if AC) waveform	Sinusoidal (distortion factor < 0.05)
Magnetic field of external origin	Terrestrial flux

**9.6. Range of Use**

Values of measured quantities, components of measured quantities, and quantities which affect measurement errors to some degree, for which the product gives meaningful readings.

Voltage	5 .. 120% of Range Maximum (below 5% of Range Maximum voltage, current indication may be only approximate.)
Current	0.1 .. 120% of nominal
Frequency	45 .. 66 Hz
Power Factor (active/reactive as appropriate)	1 .. 0 leading or lagging
Active power (Watt)	1 .. 144% of nominal, 360MW Max
Reactive power (var)	1 .. 144% of nominal, 360Mvar Max
Apparent power (VA)	1 .. 144% of nominal, 360MVA Max
Harmonic distortion (voltage)	Max 40% THD up to 31st harmonic



Power is only registered when voltage and current are within their respective range of use.

Power Factor is only indicated when the measured VA is over 3% of Range Maximum.

Voltage THD is only indicated when the measured voltage is over 5% of Range Maximum, and full accuracy only when measured voltage >25% of Range Maximum.

Current THD is only registered when the measured current is over 5% of nominal, and full accuracy only when measured current is over 20% of nominal

### 9.7. Standards

Terms, Definitions and Test Methods	IEC688:1992 (BSEN 60688)
EMC Emissions	EN61326 – Emission class A (Industrial)
EMC Immunity	EN61326 – Immunity Annex A (Industrial) ANSI 39.90
Safety	IEC1010-1 (BSEN 61010-1) Permanently connected use, Normal Condition Installation category III, pollution degree 2, Basic Insulation, for rated voltage.

### 9.8. Insulation

Dielectric voltage withstand test

- CT primary to voltage circuits 2.2kV RMS 50Hz for 1 minute
- Relay contact to voltage circuits 2.2kV RMS 50Hz for 1 minute
- RS485 to voltage circuits 3.1kV DC for 1 minute
- Analogue to voltage circuits 3.1kV DC for 1 minute
- Auxiliary supply to voltage circuits 2.7kV RMS 50Hz for 1 minute
- Base mounting to voltage circuits 2.2kV RMS 50Hz for 1 minute  
(Integra 1580 only)

CT primary to CT primary CT circuits are galvanically isolated from each other, resistance typically in excess of 100k ohms tested with a nominal voltage of 10VDC.

### 9.9. Environmental

Operating temperature	-20 to +60°C*
Storage temperature	-30 to +80°C*
Relative humidity	0 .. 90% non condensing

Warm up time	1 minute
Shock	30g in 3 planes
Vibration	10 .. 15 Hz, 1.5mm amplitude peak to peak, 15Hz to 150 Hz @ 1g

\*Maximum operating and storage temperatures are in the context of typical daily and seasonal variation. These products are not designed for permanent operation or long term storage at maximum specified temperatures

### 9.10. Enclosure

1560	DIN rail 96x96mm Length < 125mm excluding terminations, plastic moulded case.
1580	Surface Mount steel plate 96x132mm Length < 125mm excluding terminations, plastic moulded case

### 9.11. Serial Communications Option

Baud rate	19200, 9600, 4800 or 2400 (programmable)
Parity	None, Odd or Even, with 1 stop bit, or None with 2 stop bits.
Protocol	MODBUS (RS 485) or Johnson Controls N2 Ver A 1996

(Note Johnson Controls N2 specifies fixed baud rate and parity)  
Programmable Modbus word order at user option.

### 9.12. Active Energy Pulsed Output Option

Default pulse rate	1 per kWhr
Pulse rate divisors	10 (yielding 1 pulse per 10 kWhr) 100 (yielding 1 pulse per 100 kWhr) 1000 (yielding 1 pulse per 1MWh)
Pulse duration	60ms, 100ms or 200ms 3600 Pulses per Hour max

**Multiple Pulsed Output Option**

Multiple pulsed option includes kWh import, kvarh import, Import relays are located on comms card

Default pulse rate	1 per kWhr, kvarh (all outputs have common scaling)
Pulse rate divisors	10 (yielding 1 pulse per 10 kWhr/ kvarh) 100 (yielding 1 pulse per 100 kWhr/ kvarh) 1000 (yielding 1 pulse per 1MWh/ Mvarh)

**9.13. Analogue Outputs Option**

**Range**

1 or 2 channels either	0/1mA 0/5mA 0/10mA 0/20mA (user configurable as 4-20mA) -1/-0/+1mA -5/-0/+5mA
------------------------	--

For 2 channel option both ranges must be identical.

## 10. Metered Supply Connection Diagrams

Connections shown are for predominantly importing applications. CT connections may be reversed for predominantly exporting applications, with a consequent reversal of signs for Power parameters.

### European Style

3-PHASE - 4 WIRE UNBALANCED LOAD  
DIGITAL METERING SYSTEM

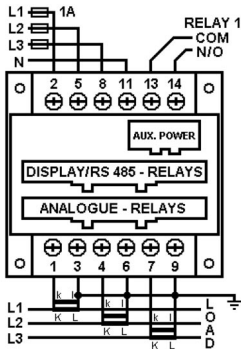

3-PHASE - 3 WIRE UNBALANCED LOAD  
DIGITAL METERING SYSTEM

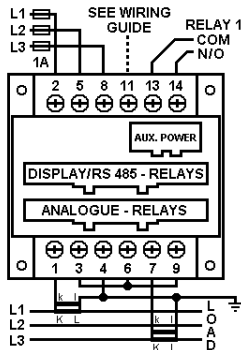

### USA Style

3-PHASE - 4 WIRE UNBALANCED LOAD  
DIGITAL METERING SYSTEM

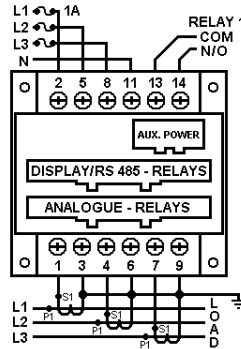

3-PHASE - 3 WIRE UNBALANCED LOAD  
DIGITAL METERING SYSTEM

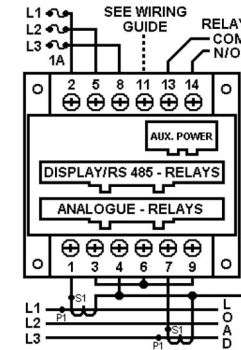

**European Style**

SINGLE PHASE - 2 WIRE  
DIGITAL METERING SYSTEM

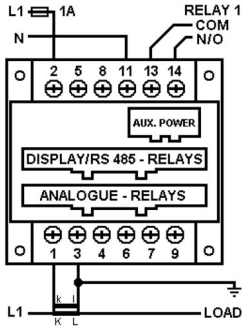

**USA Style**

SINGLE PHASE - 2 WIRE  
DIGITAL METERING SYSTEM

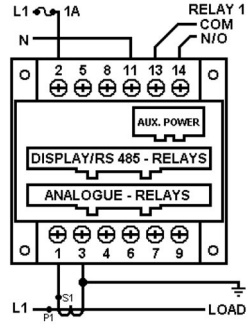

SINGLE PHASE - 3 WIRE  
DIGITAL METERING SYSTEM

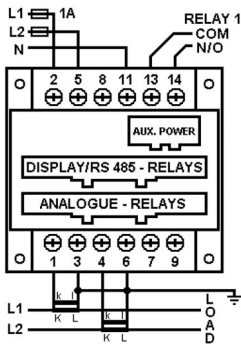

SINGLE PHASE - 3 WIRE  
DIGITAL METERING SYSTEM

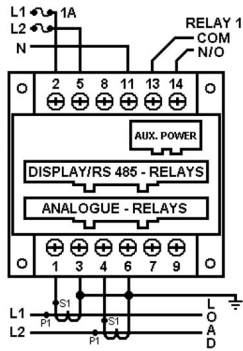

## 11. Output Connections

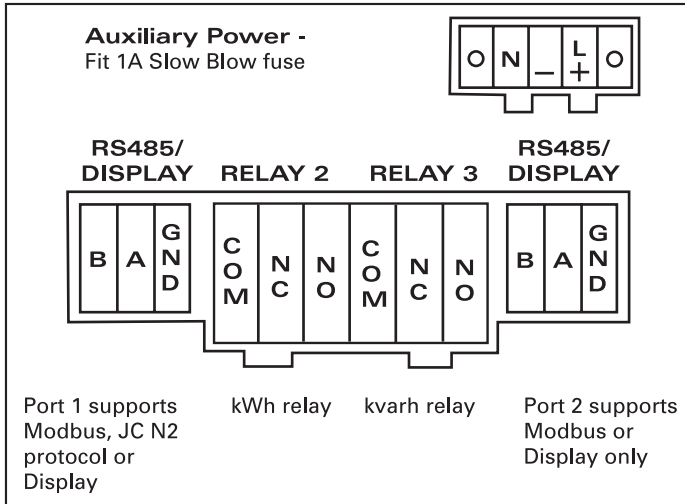

## 12. Installation and Maintenance

### 12.1. Introduction

Units should be installed in a dry position, where the ambient temperature is reasonably stable and will not be outside the range -20 to +60°C (55°C if optional outputs exceed two off communications ports). INT-1580 fixing should be by screws through the holes provided. INT-1560 fixing is direct to DIN Rail. Vibration should be kept to a minimum.

These units are intended for indoor use only at an altitude of less than 2000m.

#### Warning

- During normal operation, voltages hazardous to life may be present at some of the terminals of this unit. Installation and servicing should be performed only by qualified, properly trained personnel' abiding by local regulations. Ensure all supplies are de-energised before attempting connection or other procedures.
- It is recommended adjustments be made with the supplies de-energised, but if this is not possible, then extreme caution should be exercised.
- Terminals should not be user accessible after installation and external installation provisions must be sufficient to prevent hazards under fault conditions.
- This unit is not intended to function as part of a system providing the sole means of fault protection - good engineering practice dictates that any critical function be protected by at least two independent and diverse means.
- Never open circuit the secondary winding of an energised current transformer.

- Auxiliary circuits (12-48V auxiliary, communications, relay and analogue outputs, where applicable) are separated from metering inputs and 100-250V auxiliary circuits by at least basic insulation. Such auxiliary circuit terminals are only suitable for connection to equipment which has no user accessible live parts. The insulation for such auxiliary circuits must be rated for the highest voltage connected to the instrument and suitable for single fault condition. The connection at the remote end of such auxiliary circuits should not be accessible in normal use. Depending on application, equipment connected to auxiliary circuits may vary widely. The choice of connected equipment or combination of equipment should not diminish the level of user protection specified.
- This unit is not intended to provide safety rated isolation between the 12-48V auxiliary terminals and communications or analogue output circuits. Galvanic isolation is provided, but one of the 12-48V inputs should be at or near earth potential.
- The metal base plate on the Integra 1580 must be earthed.

## 12.2. Electromagnetic Compatibility

This unit has been designed to provide protection against EM (electro-magnetic) interference in line with requirements of EU and other regulations. Precautions necessary to provide proper operation of this and adjacent equipment will be installation dependent and so the following can only be general guidance:-

- Avoid routing wiring to this unit alongside cables and products that are, or could be, a source of interference.
- The auxiliary supply to the unit should not be subject to excessive interference. In some cases, a supply line filter may be required.
- To protect the product against incorrect operation or permanent damage, surge transients must be controlled. It is good EMC practice to suppress differential surges to 2kV or less at the source. The unit has been designed to automatically recover from typical transients, however in extreme circumstances it may be necessary to temporarily disconnect the auxiliary supply for a period of greater than 5 seconds to restore correct operation.
- Screened communication and small signal leads are recommended and may be required. These and other connecting leads may require the fitting of RF suppression components, such as ferrite absorbers, line filters etc., if RF fields cause problems.
- It is good practice to install sensitive electronic instruments that are performing critical functions in EMC enclosures that protect against electrical interference causing a disturbance in function.

## 12.3. Wiring

### Metered Supply Input

Input connections are made to screw clamp terminals. Choice of cable should meet local regulations for the operating voltage and current. Terminals for both current and voltage inputs will accept one or two 3mm<sup>2</sup> or less cross sectional area cables. This unit must be fitted with external fuses in voltage and auxiliary supply lines. Voltage input lines must be fused with a quick blow AC fuse 1A maximum. Auxiliary supply lines must be fused with a slow blow fuse rated 1A maximum. Choose fuses of a type and with a breaking capacity appropriate to the supply and in accordance with local regulations.

Where fitted, CT secondaries must be grounded in accordance with local regulations. It is desirable to make provision for shorting links to be made across CTs. This permits easy replacement of a unit should this ever be necessary.

A switch or circuit breaker allowing isolation of supplies to the unit must be provided.

Main terminal screws should be tightened to 1.35Nm or 1.0 ft/lbf only.

### Additional considerations for three wire systems

If this product is used in a system with an a.c. auxiliary where the frequency of the auxiliary may be different to the frequency of the signals being measured it will be necessary to connect the neutral terminal (terminal number 11) either to the system neutral connection or to an earth (ground) connection in order to achieve the published specifications.

The neutral terminal (terminal number 11) is indirectly connected to the voltage input terminals (terminals 2, 5 and 8). When connected to a three wire system where one of the lines has become disconnected the neutral terminal will adopt a potential somewhere between the remaining lines.

If external wiring is connected to the neutral terminal it must be connected to either the neutral line or earth (ground) to avoid the possibility of electric shock from the neutral terminal.

Standard CT wiring configurations for 3 wire systems include a commoning point. A maximum of two units, fed from a single set of CTs and with a single earth point may be wired in this way. If more units must be run from a single set of CTs then use 3 CTs and wire CT connections as for 4 wire systems. In this configuration, the number of units that may be connected is limited by the permissible CT burden.

### Output

Output connections are made directly to a two part, detachable screw clamp style connector. The choice of cable should satisfy local regulations for the operating voltage and current. This is particularly important for the relay contact wiring which may carry potentially hazardous voltages.

Detachable terminal connector screws should be tightened to 0.9Nm or 0.7 ft/lbf only.

**Optional Display**

The connections between the optional display and transducer are made directly to two-part detachable screw clamp style connectors. The recommended cable between the display and transducer is two core screened cable. Preferably select a cable specifically recommended for RS485 use (for example Belden 9860, 8761) although for shorter distances of a few metres most two core screened cables will often be satisfactory. The display to transducer communication uses RS485 and therefore cable length (transmission distance) can be up to 1200 metres in good conditions. Electrical interference or other adverse conditions may reduce the maximum cable length possible for reliable operation.

**Relay connections**

When the centre output connector is fitted, Relay 2 and Relay 3 provide output pulses with change over contacts. When only a single pulsing relay is specified, the 6 way Relay 2 / Relay 3 connector shown on the diagram in section 11 may not be fitted. On this variant, Relay 1 normally open contacts are available on the main terminal block at terminals 13 and 14 as shown on the wiring diagrams in section 10.

**12.4. Auxiliary Supply**

There are two auxiliary options available as factory build options. The auxiliary supply is marked on the unit rating label. The Integra 1560/1580 should ideally be powered from a dedicated supply, however when the 100-250 V auxiliary option is fitted it may be powered from the signal source, providing the source remains within tolerance of the medium voltage auxiliary range.

The auxiliary supply connection has terminals for both medium voltage and low voltage auxiliary. Depending on the supply option fitted either the 12-48 pair or the 100-250v pair will be operational. For 100-250 V auxiliary, connect the supply to the outer two terminals marked L and N. For 100-250 V, connections are polarity insensitive. For 12-48 V auxiliary, connect to centre and right hand (as viewed from instrument rear) terminals marked - and +. Polarity reversal will not cause damage but the instrument will not function.

100-250V AC or DC		100-250V AC or DC		
<b>O</b>	<b>N</b>	<b>-</b>	<b>L+</b>	<b>O</b>
		12-48V negative	12-48V Positive	

It is recommended that when used with an Integra 1540 display, a common auxiliary supply is used for both the display and transducer. If this arrangement is not implemented then the transducer communications parameters may be configured as detailed in the preceding section "Serial Communications". The transducer establishes contact with a display in the first 5 seconds after power up, and may not operate correctly with the display if the display is powered several seconds after the transducer is powered, unless the communications parameters are set appropriately.

## **12.5. Maintenance**

In normal use, little maintenance is needed. As appropriate for service conditions, isolate electrical power, inspect the unit and remove any dust or other foreign material present. Periodically check all connections for freedom from corrosion and screw tightness, particularly if vibration is present.

If necessary wipe the case with a dry cloth. If a cleaning agent is necessary, isopropyl alcohol is the only recommended agent and should be used sparingly. Water should not be used. If the case exterior or terminals should accidentally be contaminated with water, the unit must be thoroughly dried before further service. Should it be suspected that water might have entered the unit, factory inspection and refurbishment is recommended.

In the unlikely event of a repair being necessary, it is recommended that the unit be returned to the factory or nearest Crompton service centre.

**Case Dimension**

**INT-1560 Case Dimensions – DIN Rail Mounting**

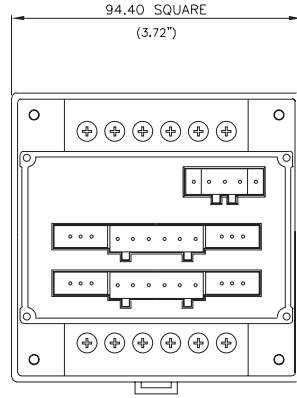
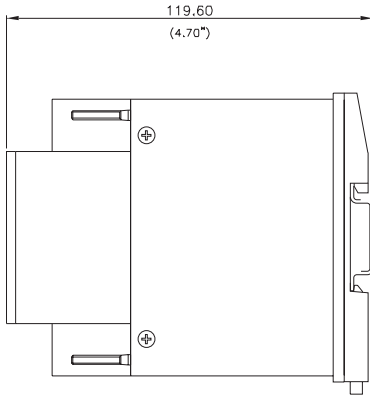

ALL DIMENSION ARE IN MILLIMETRES  
(IMPERIAL EQUIVALENTS SHOWN IN BRACKETS)

**INT-1580 Case Dimensions – Surface Mounting**

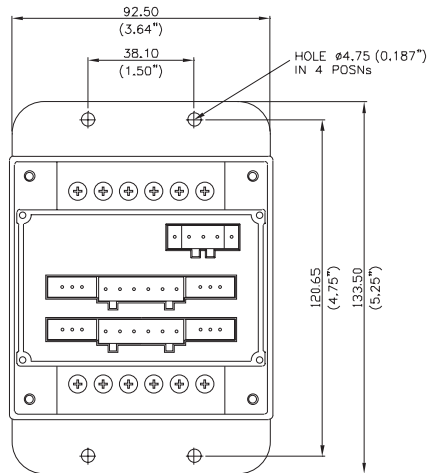
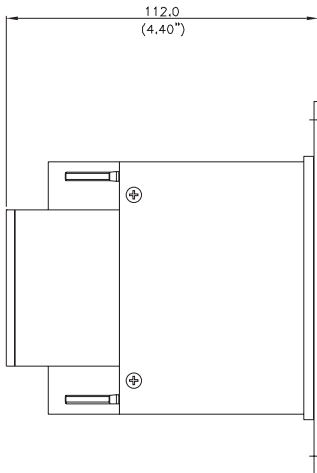

ALL DIMENSION ARE IN MILLIMETRES  
(IMPERIAL EQUIVALENTS SHOWN IN BRACKETS)

**tyco**

Electronics

**Energy Division**

Tyco Electronics UK Limited  
Crompton Instruments  
Freebournes Road, Witham,  
Essex, CM8 3AH, UK

Tel.: +44 1376 509 509  
Fax: +44 1376 509 511

## DECLARATION OF CONFORMITY

**Manufacturer's Name:** Tyco Electronics UK Limited - Crompton Instruments  
**Manufacturer's Address:** Freebournes Road, Witham, Essex, CM8 3AH, UK

**declares that the products:**

**Product Names:** Integra 1560 Transducer and display  
**Model Numbers:** INT-1561, INT-1562, INT-1563, INT-1564, INT-1581, INT-1582,  
INT-1583, INT-1584, DIS-0240, DIS-0340, DIS-0640, DIS-0740,  
DIS-1540

**conforms to the following standards:**

**LVD:**

**BS EN 61010-1 : 1993 Plus Amendment 2 (July 1995)**

Safety Requirements for Electrical Equipment for Measurement, Control, and Laboratory Use

**EMC:**

**BS EN 61326: 1998A1** Emissions standard for Measurement Control and Laboratory Equipment, Class A

**BS EN 61326: 1998A1** Immunity standard for Measurement Control and Laboratory Equipment, Annex A

**Supplementary Information:**

The product complies with the requirements of the following EU directives and carries CE marking accordingly

- **European Low Voltage Directive 73/23/EEC** amended by **93/69/EEC** by the standards route to compliance.
- **EMC Directive 89/336/EEC**, amended by **93/68/EEC**, by the standards route to compliance.

Signature of authorised person.

**N F Dudley**  
**R&D Manager**



Dated: 30 April 2002



FM 21540

Registered Office: Faraday Road, Dorcan,  
Swindon, Wiltshire, SN3 5HH, UK  
Registered No. 550926  
VAT No. GB 681 471 425

---

The Information contained in these installation instructions is for use only by installers trained to make electrical power installations and is intended to describe the correct method of installation for this product. However, Tyco Electronics has no control over the field conditions which influence product installation.

It is the user's responsibility to determine the suitability of the installation method in the user's field conditions. Tyco Electronics' only obligations are those in Tyco Electronics' standard Conditions of Sale for this product and in no case will Tyco Electronics be liable for any other incidental, indirect or consequential damages arising from the use or misuse of the products. Crompton is a trade mark.

---



**Tyco Electronics UK Limited**  
**Crompton Instruments**

Freebournes Road, Witham, Essex, CM8 3AH, UK  
Tel: +44 1376 509 509 Fax: +44 1376 509 511

<http://energy.tycoelectronics.com>