

Products Covered

244-30* 077-30* * = Any letter or number

Installation

Units should be mounted in a reasonably stable ambient temperature within the range 0 to 60°C.

The units should not be mounted where they will be subjected to excessive sunlight and vibration should be kept to a minimum. Connection wires should be sized to comply with local regulations and preferably should be fitted with tags for the terminals provided. Labels are fixed to the units and carry connection-input information. The fitting of external fuses is recommended since there are no internal fuses.

Set Point Operation

To obtain optimum accuracy the red pointers must be adjusted upscale to the desired scale value.

Example on Meter Scaled 0/100%:-

- If the desired set point is 20%, adjust the red pointer below this level, eg: 15%
- Adjust the red pointer clockwise (upscale) to 20%

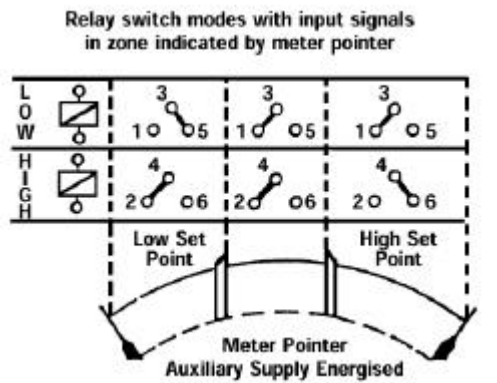

Fusing and Connections

1. This unit must be fitted with external fuses in voltage and auxiliary supply lines.
2. Voltage input lines must be fused with a quick blow fuse 1A maximum.
3. Auxiliary supply lines must be fused with a slow blow fuse rated 1A maximum.
4. Choose fuses of a type and with a breaking capacity appropriate to the supply and in accordance with local regulations.
5. Where fitted, CT secondaries must be grounded in accordance with local regulations.

Screw Torque

Main terminal screws should be tightened to 1.35Nm or 1.0 ft/lbf only. Detachable terminal connector screws should be tightened to 0.9Nm or 0.7 ft/lbf only. Where fitted, terminal covers are held in place by miniature self tapping screws into plastic. These screws should be tightened by hand only, sufficiently to secure the terminal cover and prevent it vibrating.

**Analogue Meter Relays
Switchboard 077 Series &
DIN Panel Mounted 244 Series**

Maintenance

All units are fully calibrated before despatch and therefore no adjustments are required. During routine servicing and inspection of equipment the unit should be inspected to normal standards for this class of equipment. For example remove accumulations of dust and check connections for tightness and corrosion. In the event of a fault occurring and repair being necessary, it is recommended that the instruments be returned the factory or to the nearest Crompton Instruments Sales and Service Centre.

Electromagnetic Compatibility

This unit has been designed to provide protection against EM (electro-magnetic) interference in line with requirements of EU and other regulations. Precautions necessary to provide proper operation of this and adjacent equipment will be installation dependent and so the following can only be general guidance:-

- Avoid routing wiring to this unit alongside cables and products that are, or could be, a source of interference.
- The auxiliary supply to the unit should not be subject to excessive interference. In some cases, a supply line filter may be required.
- To protect the product against incorrect operation or permanent damage, surge transients must be controlled. It is good EMC practice to suppress differential surges to 2kV or less at the source. The unit has been designed to automatically recover from typical transients, however in extreme circumstances it may be necessary to temporarily disconnect the auxiliary supply for a period of greater than 5 seconds to restore correct operation.
- Screened communication and small signal leads are recommended and may be required. These and other connecting leads may require the fitting of RF suppression components, such as ferrite absorbers, line filters etc., if RF fields cause problems.

It is good practice to install sensitive electronic instruments that are performing critical functions in EMC enclosures that protect against electrical interference causing a disturbance in function.

Warning

- During normal operation, voltages hazardous to life may be present at some of the terminals of this unit. Installation and servicing should be performed only by qualified, properly trained personnel' abiding by local regulations. Ensure all supplies are de-energised before attempting connection or other procedures.
- It is recommended adjustments be made with the supplies de-energised, but if this is not possible, then extreme caution should be exercised.
- Terminals should not be user accessible after installation and external installation provisions must be sufficient to prevent hazards under fault conditions.
- This unit is not intended to function as part of a system providing the sole means of fault protection - good engineering practice dictates that any critical function be protected by at least two independent and diverse means.
- Never open circuit the secondary winding of an energised current transformer.



INSTALLATION INSTRUCTIONS

Analogue Meter Relays Switchboard 077 Series & DIN Panel Mounted 244 Series

077 Series Connections

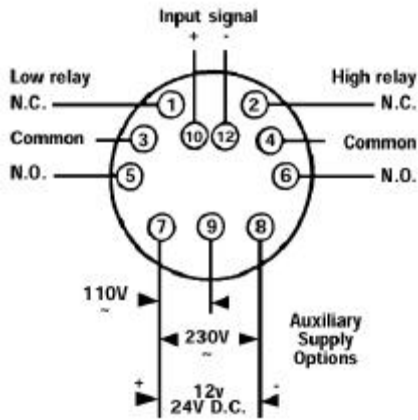

244 Series Connections

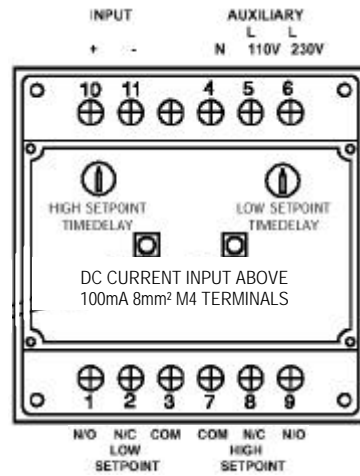

077 Series Dimensions and Cut Out

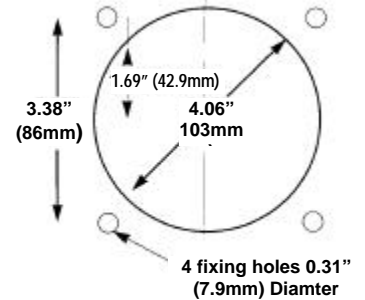
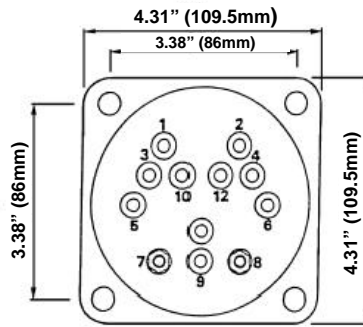
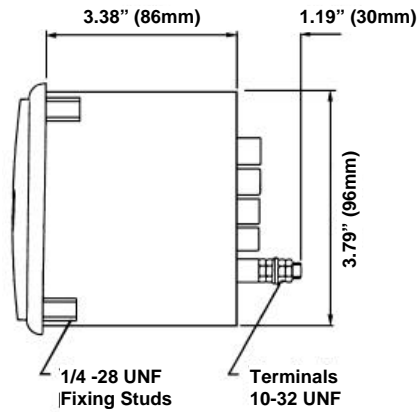

244 Series Dimensions and Cut Out

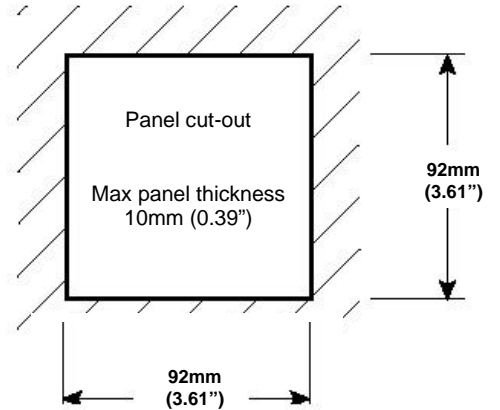
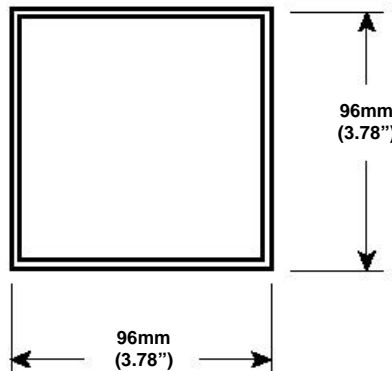
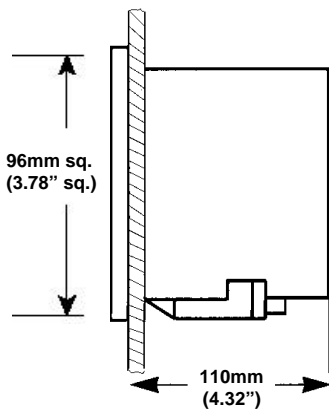

The Information contained in these installation instructions is for use only by installers trained to make electrical power installations and is intended to describe the correct method of installation for this product. However, Tyco Electronics has no control over the field conditions, which influence product installation. It is the user's responsibility to determine the suitability of the installation method in the user's field conditions. Tyco Electronics' only obligations are those in Tyco Electronics' standard Conditions of Sale for this product and in no case will Tyco Electronics be liable for any other incidental, indirect or consequential damages arising from the use or misuse of the products. Crompton is a trademark.



Tyco Electronics UK Limited

Crompton Instruments

Freebournes Road, Witham, Essex, CM8 3AH, UK

Phone: +44 1376 509 509 Fax: +44 1376 509 511

<http://energy.tycoelectronics.com>

INSTALLATION INSTRUCTIONS

Analogue Meter Relays Panel Mounted 239 Series

Screw Torque

Main terminal screws should be tightened to 1.35Nm or 1.0 ft/lbf only. Detachable terminal connector screws should be tightened to 0.9Nm or 0.7 ft/lbf only. Where fitted, terminal covers are held in place by miniature self tapping screws into plastic. These screws should be tightened by hand only, sufficiently to secure the terminal cover and prevent it vibrating.

Maintenance

Unless a fault develops, the unit requires little attention. During routine servicing and inspection of the associated equipment, the device should be inspected to normal standards for this class of equipment. For example remove accumulations of dust and check all connections for tightness and corrosion.

Electromagnetic Compatibility

This unit has been designed to provide protection against EM (electromagnetic) interference in line with requirements of EU and other regulations. Precautions necessary to provide proper operation of this and adjacent equipment will be installation dependent and so the following can only be general guidance:-

- Avoid routing wiring to this unit alongside cables and products that are, or could be, a source of interference.
- The auxiliary supply to the unit should not be subject to excessive interference. In some cases, a supply line filter may be required.
- To protect the product against incorrect operation or permanent damage, surge transients must be controlled. It is good EMC practice to suppress differential surges to 2kV or less at the source. The unit has been designed to automatically recover from typical transients, however in extreme circumstances it may be necessary to temporarily disconnect the auxiliary supply for a period of greater than 5 seconds to restore correct operation.
- Screened communication and small signal leads are recommended and may be required. These and other connecting leads may require the fitting of RF suppression components, such as ferrite absorbers, line filters etc., if RF fields cause problems.
- It is good practice to install sensitive electronic instruments that are performing critical functions in EMC enclosures that protect against electrical interference causing a disturbance in function.

Warning

- During normal operation, voltages hazardous to life may be present at some of the terminals of this unit. Installation and servicing should be performed only by qualified, properly trained personnel' abiding by local regulations. Ensure all supplies are de-energised before attempting connection or other procedures.
- It is recommended adjustments be made with the supplies de-energised, but if this is not possible, then extreme caution should be exercised.
- Terminals should not be user accessible after installation and external installation provisions must be sufficient to prevent hazards under fault conditions.
- This unit is not intended to function as part of a system providing the sole means of fault protection - good engineering practice dictates that any critical function be protected by at least two independent and diverse means.
- Never open circuit the secondary winding of an energised current transformer.

Dimensions and Panel Cut Out

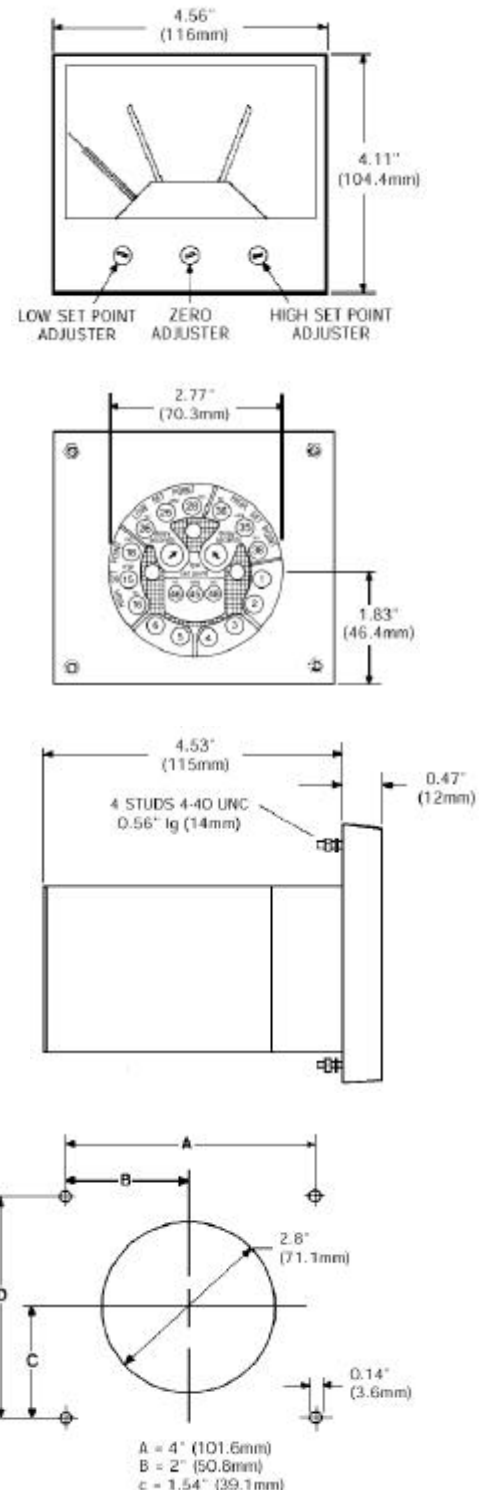

The Information contained in these installation instructions is for use only by installers trained to make electrical power installations and is intended to describe the correct method of installation for this product. However, Tyco Electronics has no control over the field conditions, which influence product installation. It is the user's responsibility to determine the suitability of the installation method in the user's field conditions. Tyco Electronics' only obligations are those in Tyco Electronics' standard Conditions of Sale for this product and in no case will Tyco Electronics be liable for any other incidental, indirect or consequential damages arising from the use or misuse of the products. Crompton is a trademark.



Tyco Electronics UK Limited

Crompton Instruments

Freebournes Road, Witham, Essex, CM8 3AH, UK

Phone: +44 1376 509 509 Fax: +44 1376 509 511

<http://energy.tycoelectronics.com>