



Features

- Adjustable setpoint
- Adjustable differential
- LED trip indication
- Double pole relay contacts
- Automatic reset

Benefits

- Over and under frequency monitoring
- Over and underspeed monitoring
- Start standby generators
- Operation of mains failure units
- Switching standby supplies
- Protection of control gear
- Nuisance tripping avoidance
- Customized options

Applications

- Marine panels
- Switchgear
- Distribution systems
- Generator sets
- Control panels
- Process control
- Motor protection
- Transformers
- Overload protection

Approvals

UL, CSA, BV and ABS

Frequency

Crompton frequency protectors give continuous surveillance of the monitored circuit. When the frequency moves outside the set point limit the relay will operate giving an alarm, control or tripping signal. An illuminated LED indicates when the relay is energized. Since speed is proportional to the frequency, this protector can be used to monitor over and underspeed, and to protect mains supplies, computer supplies, and standby supplies for Industrial, Hospital or Marine use.

Operation

Frequency protectors offer user adjustable frequency trip point (setpoint) and differential (hysteresis) settings. The setpoint adjustment range is centred around the nominal 50Hz, 60Hz or 400Hz system frequency. The differential setting adjustment can be used to reduce nuisance tripping if the measured signal is noisy or unstable. When the measured frequency moves outside the setpoint limit, the relay will operate, giving an alarm or initiation signal. As soon as the monitored frequency moves outside of the setpoint limit, a trip will occur. The units draw their operating power from the measuring inputs. Combined units offer under and over frequency trips in one compact unit. Single function units are also available.

Over Frequency Models

When the monitored frequency exceeds the setpoint, the relay will energize and the red LED will illuminate to indicate the trip condition. The relay will automatically reset once the monitored frequency falls below the setpoint minus the differential. When reset, the LED will extinguish and the relay de-energizes.

Under Frequency Models

When the monitored frequency falls below the setpoint, the relay will de-energize and the red LED will extinguish to indicate the trip condition. The relay will automatically reset once the monitored frequency rises above the setpoint plus the differential. When reset, the LED will illuminate and the relay energizes.

Options

250 series protector relays offer various customized options to suit individual requirements. Please consult factory.

- Adjustment ranges - different adjustment ranges are possible for the setpoint and differential controls.
- Time delay - internal fixed time delay before a trip occurs.
- Relay operation - standard models are fail safe, but the relays can be customized to energize or de-energize on trip.

Product Codes

Relay	Protection	ANSI No.	Catalog No.
Single phase	Under frequency	81U	252-PHU
Single phase	Over frequency	81O	252-PHO
Single phase	Under and over frequency	81O/U	253-PHD

Specify system voltage, frequency and required options at time of ordering.

250 Series DIN Rail and Wall Mounted Relays

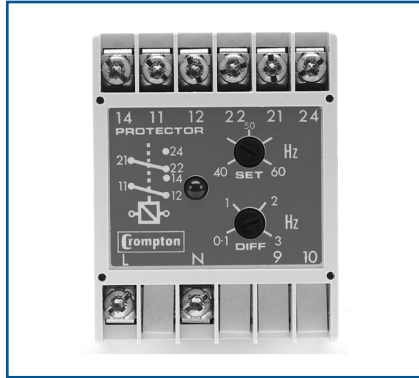

Connections

252-PHU
252-PHO

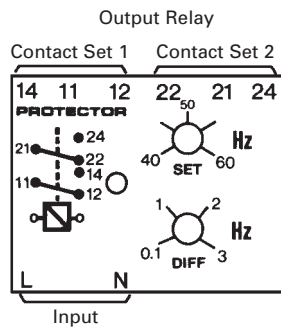

253-PHD

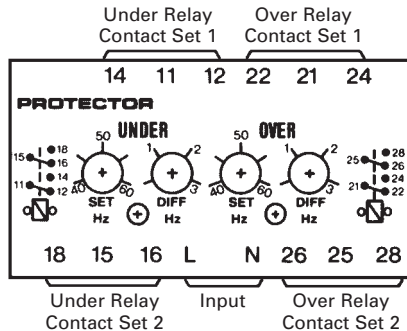

Specification – Frequency

Nominal Voltage	100V, 110V, 120V, 208V, 220V, 230V, 240V, 277V, 380V, 400V, 415V, 440V or 480V ± 20%
System Frequency	40/60Hz, 50/70Hz or 360/440Hz
Voltage Burden	3VA
Overloads	1.2 x rating continuously, 1.5 x rating for 10 x seconds
Set Point Repeatability	>0.5% of full span
Differential (Hysteresis)	40/60Hz, 50/70Hz: Adjustable 0.1 to 3.0Hz 360/440Hz: Adjustable 10 to 30Hz
Output Relay	Double pole change over
Relay Contact Rating	AC: 240V 5A, non inductive DC: 24V, 5A resistive
Relay Mechanical Life	0.2 million operations at rated loads
Relay Reset	Automatic
Operating Temperature	0°C to +60°C (0°C to +40°C for UL models)
Storage Temperature	-20°C to +70°C
Temperature Co-efficient	0.05% per °C
Interference Immunity	Electrical stress surge withstand and non-function to ANSI/IEEE C37 90a
Enclosure Style	DIN rail with wall mounting facility
Material	Flame retardant polycarbonate/ABS
Enclosure Integrity	IP50
Compliant With	EMC, LVD, Safety Standard IEC 414 UL File No: E113067 recognized up to 600V CSA File No: LR52592 up to 400Hz 300V BV File No: 2650H-07427-AO PRSO BV ABS File No: 93-LD 17806-X
Model 252 Dimensions	55mm (2.2") wide x 70mm (2.8") high x 112mm (4.4") deep
Model 253 Dimensions	75mm (2.9") wide x 70mm (2.8") high x 112mm (4.4") deep
Weight	Model 252: 0.4Kg approx. Model 253: 0.6Kg approx

Dimensions

Model 252

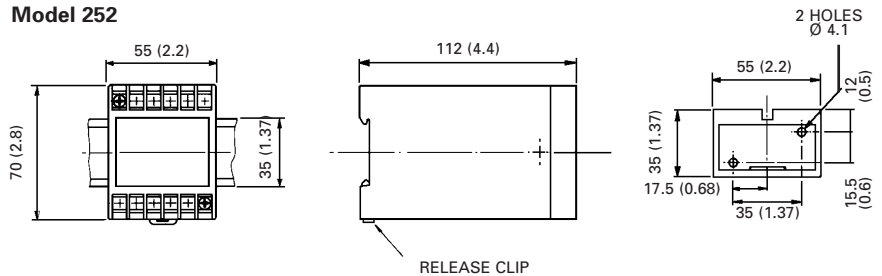

Model 253

