

## Features

- 1mA analog output
- 3 adjustable setpoints
- Adjustable time delay
- Internal differential
- LED trip indication
- Automatic reset
- 3 single pole relays
- Magnetic pick up input

## Benefits

- Under/over speed monitoring
- Speed indicator output signal
- Zero reset cranking
- Nuisance tripping avoidance
- Customized options

## Applications

- Marine panels
- Switchgear
- Distribution systems
- Generator sets
- Control panels
- Process control
- Motor protection
- Transformers
- Overload protection

## Approvals

- UL recognized

## Speed Sensing

The 250 series speed sensing relay monitors rotating equipment and provides three output contacts which can be used to initiate alarm or shutdown signals. The relay also provides a tachometer output for speed indication. Speed sensing relays are ideally suited for engine and gas turbine monitoring and the protection of generator sets.

## Operation

The speed sensing protector monitors the speed of rotation using a low cost magnetic pickup. Speed sensors are often used in generator set engines, gas turbines, motors, gear boxes or any rotating machines. The relay will detect under speed, over speed and stopped conditions, and the setpoint relays can be used to raise an alarm or shut down the equipment. The relay provides three user adjustable trip levels with LED relay state indication and a speed indicator output signal.

The product also offers an analog output that can be used to monitor or display the speed. The product operates from the 12V or 24V dc battery supply, and speed is measured and calculated from the number of sensor pulses per revolution. Since the sensor is magnetic, a rotating steel component can be used, such as the flywheel which has gear teeth. This will result in a large number of pulses per revolution, and lead to greater accuracy.

The protector continuously monitors the rotation speed, and updates the analog output signal. An output of 0.75 mA indicates normal speed (100%) while 1mA indicates 133% of nominal speed. The calibration point can easily be user adjusted. Three setpoint control adjustments allow setting of the desired speed limits for cranking, under speed and over speed.

### Cranking Relay

The cranking relay detects if the engine is running or stopped. This relay can be used to ensure the cranking motor is disconnected once the engine has started running. Set the cranking setpoint just above the cranking motor speed. A red LED illuminates when the relay is energized, indicating a trip condition. The crank relay will only reset when the input frequency falls below 20% of the crank set point.

### Under Speed Relay

The under speed relay detects when the normal running speed has been achieved. This can be used to enable the generator's electrical protection. It can also be used to trigger load shedding. A red LED illuminates when an under speed condition exists.

### Over Speed Relay

The overspeed relay detects a stuck throttle or overshoot, a break in the sensor load will de-energize the over speed relay and can be used to shut down the engine. A red LED indicates over speed trip.

### Fail Safe Operation

The relay will detect an open circuit speed sensor, and de-energize the overspeed relay.

## Product Codes

Relay	Protection	ANSI No.	Catalog No.
Speed Sensing	Crank 10 to 50% Under speed 50 to 100% Over speed 100 to 130%	12/14	253-PH3

When ordering please supply the following information:

- The number of pulses per revolution, e.g. flywheel teeth = 30.
- The nominal running speed, e.g. 3600 RPM.
- The DC battery supply, e.g. 24 V dc.

The protector speed sensing relay provides three user adjustable trip levels with LED relay state indication and a speed indicator output signal. Please specify:

- SP1 - disengages the crank starter.
- SP2 - energizes protection or under-speed alarm.
- SP3 - alarms or trips on overspeed.

# 250 Series DIN Rail and Wall Mounted Relays



## Connections

### 253-PH3

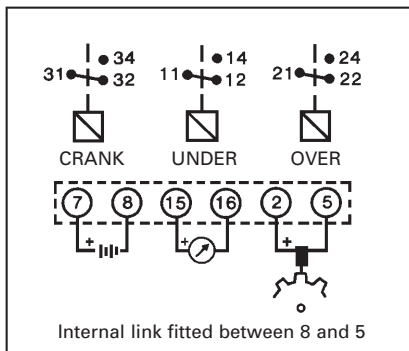

## Specification – Speed Sensing

Pulse Input (Magnetic Input)	5V – 75V peak to peak
Frequency Input	0-1 to 0-10kHz
Overload	1.2 x rating continuously
Set Point Repeatability	>0.5% of full span
Differential (Hysteresis)	Preset at 2% (SP1 version resets at 20% of setting)
Trip Level Adjustment	SP1 (crank): 10% to 50% SP2 (under speed) : 50% to 100% SP3 (over speed) 100% to 130%
AC Auxiliary Supply Voltage	100V, 110V, 120V, 208V, 220V, 240V, 480V, ±20%
DC Auxiliary Supply Voltage	12V or 24V ±20%
Auxiliary Voltage Burden	3VA (max)
Analog Output	0.75mA for normal 100% speed. 1mA for 133% of nominal speed
Calibration Signal	0-1mA into 0-1000 ohms
Output Relay	3 single pole change over relays
Relay Contact Rating	AC: 240V 5A, non inductive DC: 24V, 5A resistive
Relay Mechanical Life	0.2 million operations at rated loads
Relay Reset	Automatic
Operating Temperature	0°C to +60°C (0°C to +40°C for UL models)
Storage Temperature	-20°C to + 70°C
Temperature Co-efficient	0.05% per °C
Interference Immunity	Electrical stress surge withstand and non-function to ANSI/IEEE C37 90a
Enclosure Style	DIN rail with wall mounting facility
Material	Flame retardant polycarbonate/ABS
Enclosure Integrity	IP50
Compliant With	EMC, LVD, Safety Standard IEC 414 UL File No: E113067 recognized up to 600V
Model 253 Dimensions	75mm (2.9") wide x 70mm (2.8") high x 112mm (4.4") deep
Weight	0.6Kg approx

## Dimensions

### Model 253

